

ESP32-C6-MINI-1

ESP32-C6-MINI-1U

Datasheet

Module that supports 2.4 GHz Wi-Fi 6 (802.11 ax), Bluetooth® 5 (LE), Zigbee and Thread (802.15.4)

Built around ESP32-C6 series of SoCs, 32-bit RISC-V single-core microprocessor

4 MB flash in chip package

22 GPIOs, rich set of peripherals

On-board PCB antenna or external antenna connector



ESP32-C6-MINI-1



ESP32-C6-MINI-1U



Pre-release v0.6
Espressif Systems
Copyright © 2023

1 Module Overview

Note:

Check the link or the QR code to make sure that you use the latest version of this document:

https://espressif.com/documentation/esp32-c6-mini-1_mini-1u_datasheet_en.pdf



1.1 Features

CPU and On-Chip Memory

- ESP32-C6FH4 embedded, 32-bit RISC-V single-core microprocessor, up to 160 MHz
- ROM: 320 KB
- HP SRAM: 512 KB
- LP SRAM: 16 KB
- 4 MB flash in chip package

Wi-Fi

- 1T1R in 2.4 GHz band
- Operating frequency: 2412 ~ 2484 MHz
- IEEE 802.11ax-compliant
 - 20 MHz-only non-AP mode
 - MCS0 ~MCS9
 - Uplink and downlink OFDMA, especially suitable for simultaneous connections in high-density environments
 - Downlink MU-MIMO (multi-user, multiple input, multiple output) to increase network capacity
 - Beamformee that improves signal quality
 - Channel quality indication (CQI)
 - DCM (dual carrier modulation) to improve link robustness
 - Spatial reuse to maximize parallel transmissions
 - Target wake time (TWT) that optimizes power saving mechanisms

- Fully compatible with IEEE 802.11b/g/n protocol
 - 20 MHz and 40 MHz bandwidth
 - Data rate up to 150 Mbps
 - Wi-Fi Multimedia (WMM)
 - TX/RX A-MPDU, TX/RX A-MSDU
 - Immediate Block ACK
 - Fragmentation and defragmentation
 - Transmit opportunity (TXOP)
 - Automatic Beacon monitoring (hardware TSF)
 - 4 × virtual Wi-Fi interfaces
 - Simultaneous support for Infrastructure BSS in Station mode, SoftAP mode, Station + SoftAP mode, and promiscuous mode
Note that when ESP32-C6 scans in Station mode, the SoftAP channel will change along with the Station channel
 - 802.11mc FTM

Bluetooth

- Bluetooth LE: Bluetooth 5.3 certified
- Bluetooth mesh
- High power mode (20 dBm)
- Speed: 125 Kbps, 500 Kbps, 1 Mbps, 2 Mbps
- Advertising extensions
- Multiple advertisement sets
- Channel selection algorithm #2
- LE power control

- Internal co-existence mechanism between Wi-Fi and Bluetooth to share the same antenna

Note:

* Please refer to [ESP32-C6 Series Datasheet](#) for detailed information about the module peripherals.

IEEE 802.15.4

- Compliant with IEEE 802.15.4-2015 protocol
- OQPSK PHY in 2.4 GHz band
- Data rate: 250 Kbps
- Thread 1.3
- Zigbee 3.0

Peripherals

- GPIO, SPI, parallel IO interface, UART, I2C, I2S, RMT (TX/RX), pulse counter, LED PWM, USB Serial/JTAG controller, MCPWM, SDIO2.0 slave controller, GDMA, TWAI[®] controller, on-chip debug functionality via JTAG, event task matrix, ADC, temperature sensor, general-purpose timers, watchdog timers, etc.

Integrated Components on Module

- 40 MHz crystal oscillator

Antenna Options

- On-board PCB antenna (ESP32-C6-MINI-1)
- External antenna via a connector (ESP32-C6-MINI-1U)

Operating Conditions

- Operating voltage/Power supply: 3.0 ~ 3.6 V
- Operating ambient temperature:
 - 85 °C version module: –40 ~ 85 °C
 - 105 °C version module: –40 ~ 105 °C

1.2 Description

ESP32-C6-MINI-1 and ESP32-C6-MINI-1U are two powerful, general-purpose Wi-Fi, IEEE 802.15.4, and Bluetooth LE modules. The rich set of peripherals and high performance make the module an ideal choice for smart homes, industrial automation, health care, consumer electronics, etc.

ESP32-C6-MINI-1 comes with a PCB antenna. ESP32-C6-MINI-1U comes with a connector for an external antenna. They both feature a 4 MB SPI flash.

Both ESP32-C6-MINI-1 and ESP32-C6-MINI-1U come in two versions:

- 85 °C version
- 105 °C version

The two versions only vary in maximum ambient temperature. In this datasheet unless otherwise stated, ESP32-C6-MINI-1 refers to the ESP32-C6-MINI-1 module in 85 °C and 105 °C versions, and ESP32-C6-MINI-1U refers to the ESP32-C6-MINI-1U module in 85 °C and 105 °C versions.

The series comparison for the two modules is as follows:

Table 1: ESP32-C6-MINI-1 (ANT) Series Comparison¹

Ordering Code	Flash ³	Ambient Temp. ¹ (°C)	Size ² (mm)
ESP32-C6-MINI-1-N4	4 MB (Quad SPI)	–40 ~ 85	13.2 × 16.6 × 2.4
ESP32-C6-MINI-1-H4		–40 ~ 105	

¹ This table shares the same notes presented in Table 2 below.

Table 2: ESP32-C6-MINI-1U (CONN) Series Comparison

Ordering Code	Flash ³	Ambient Temp. ¹ (°C)	Size ² (mm)
ESP32-C6-MINI-1U-N4	4 MB (Quad SPI)	-40 ~ 85	13.2 × 12.5 × 2.4
ESP32-C6-MINI-1U-H4		-40 ~ 105	

¹ Ambient temperature specifies the recommended temperature range of the environment immediately outside the Espressif module.

² For details, refer to Section [8.1 Physical Dimensions](#).

³ The flash is integrated in the chip's package.

At the core of the modules is ESP32-C6FH4, a 32-bit RISC-V single-core processor.

ESP32-C6FH4 integrates a rich set of peripherals including SPI, parallel IO interface, UART, I2C, I2S, RMT (TX/RX), LED PWM, USB Serial/JTAG controller, MCPWM, SDIO2.0 slave controller, GDMA, TWAI[®] controller, on-chip debug functionality via JTAG, event task matrix, as well as up to 23 GPIOs, etc.

Note:

* For more information on ESP32-C6FH4, please refer to [ESP32-C6 Series Datasheet](#).

1.3 Applications

- [Smart Home](#)
- [Industrial Automation](#)
- [Health Care](#)
- [Consumer Electronics](#)
- Smart Agriculture
- POS machines
- Service robot
- Audio Devices
- Generic Low-power IoT Sensor Hubs
- Generic Low-power IoT Data Loggers

Contents

1	Module Overview	2
1.1	Features	2
1.2	Description	3
1.3	Applications	4
2	Block Diagram	9
3	Pin Definitions	10
3.1	Pin Layout	10
3.2	Pin Description	10
3.3	Strapping Pins	11
3.3.1	SDIO Sampling and Driving Clock Edge Control	13
3.3.2	Chip Boot Mode Control	13
3.3.3	ROM Messages Printing Control	13
3.3.4	JTAG Signal Source Control	14
4	Electrical Characteristics	15
4.1	Absolute Maximum Ratings	15
4.2	Recommended Operating Conditions	15
4.3	DC Characteristics (3.3 V, 25 °C)	15
4.4	Current Consumption Characteristics	16
4.4.1	Current Consumption in Active Mode	16
4.4.2	Current Consumption in Other Modes	17
5	RF Characteristics	18
5.1	Wi-Fi Radio (2.4 GHz/5 GHz)	18
5.1.1	Wi-Fi RF Transmitter (TX) Characteristics	18
5.1.2	Wi-Fi RF Receiver (RX) Characteristics	19
5.2	Bluetooth 5 (LE) Radio	21
5.2.1	Bluetooth LE RF Transmitter (TX) Characteristics	21
5.2.2	Bluetooth LE RF Receiver (RX) Characteristics	22
5.3	802.15.4 Radio	24
5.3.1	802.15.4 RF Transmitter (TX) Characteristics	25
5.3.2	802.15.4 RF Receiver (RX) Characteristics	25
6	Module Schematics	26
7	Peripheral Schematics	28
8	Physical Dimensions and PCB Land Pattern	29
8.1	Physical Dimensions	29
8.2	Recommended PCB Land Pattern	30
8.3	Dimensions of External Antenna Connector	32

9	Product Handling	33
9.1	Storage Conditions	33
9.2	Electrostatic Discharge (ESD)	33
9.3	Soldering Profile	33
	9.3.1 Reflow Profile	33
9.4	Ultrasonic Vibration	34
10	Related Documentation and Resources	35
	Revision History	36

List of Tables

1	ESP32-C6-MINI-1 (ANT) Series Comparison	3
2	ESP32-C6-MINI-1U (CONN) Series Comparison	4
3	Pin Definitions	10
4	Default Configuration of Strapping Pins	12
5	Description of Timing Parameters for the Strapping Pins	12
6	SDIO Input Sampling Edge/Output Driving Edge Control	13
7	Boot Mode Control	13
8	ROM Messages Printing Control	14
9	JTAG Signal Source Control	14
10	Absolute Maximum Ratings	15
11	Recommended Operating Conditions	15
12	DC Characteristics (3.3 V, 25 °C)	15
13	Current Consumption for Wi-Fi (2.4 GHz) in Active Mode	16
14	Current Consumption for Bluetooth LE in Active Mode	16
15	Current Consumption for 802.15.4 in Active Mode	16
16	Current Consumption in Modem-sleep Mode	17
17	Current Consumption in Low-Power Modes	17
18	Wi-Fi RF Characteristics	18
19	TX Power with Spectral Mask and EVM Meeting 802.11 Standards	18
20	TX EVM Test	18
21	RX Sensitivity	19
22	Maximum RX Level	20
23	RX Adjacent Channel Rejection	20
24	Bluetooth LE RF Characteristics	21
25	Bluetooth LE - Transmitter Characteristics - 1 Mbps	21
26	Bluetooth LE - Transmitter Characteristics - 2 Mbps	21
27	Bluetooth LE - Transmitter Characteristics - 125 Kbps	22
28	Bluetooth LE - Transmitter Characteristics - 500 Kbps	22
29	Bluetooth LE - Receiver Characteristics - 1 Mbps	22
30	Bluetooth LE - Receiver Characteristics - 2 Mbps	23
31	Bluetooth LE - Receiver Characteristics - 125 Kbps	24
32	Bluetooth LE - Receiver Characteristics - 500 Kbps	24
33	802.15.4 RF Characteristics	24
34	802.15.4 Transmitter Characteristics - 250 Kbps	25
35	802.15.4 Receiver Characteristics - 250 Kbps	25

List of Figures

1	ESP32-C6-MINI-1 Block Diagram	9
2	ESP32-C6-MINI-1U Block Diagram	9
3	Pin Layout (Top View)	10
4	Visualization of Timing Parameters for the Strapping Pins	13
5	ESP32-C6-MINI-1 Schematics	26
6	ESP32-C6-MINI-1U Schematics	27
7	Peripheral Schematics	28
8	ESP32-C6-MINI-1 Physical Dimensions	29
9	ESP32-C6-MINI-1U Physical Dimensions	29
10	ESP32-C6-MINI-1 Recommended PCB Land Pattern	30
11	ESP32-C6-MINI-1U Recommended PCB Land Pattern	31
12	Dimensions of External Antenna Connector	32
13	Reflow Profile	33

2 Block Diagram

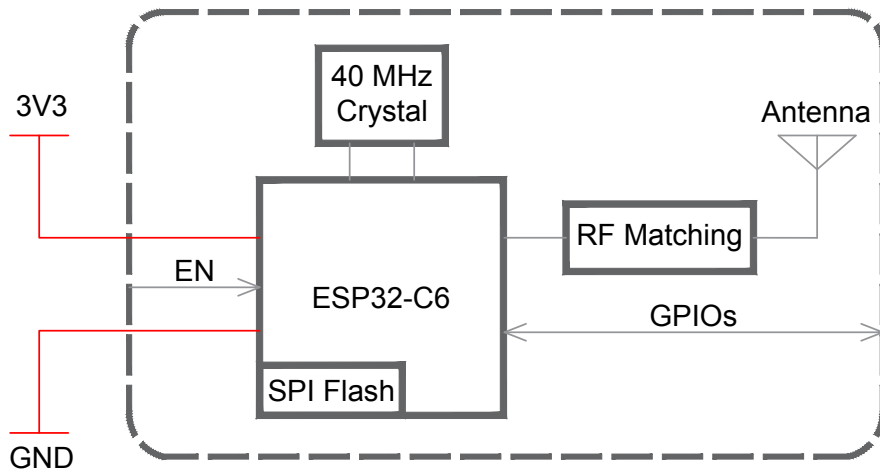

Figure 1: ESP32-C6-MINI-1 Block Diagram

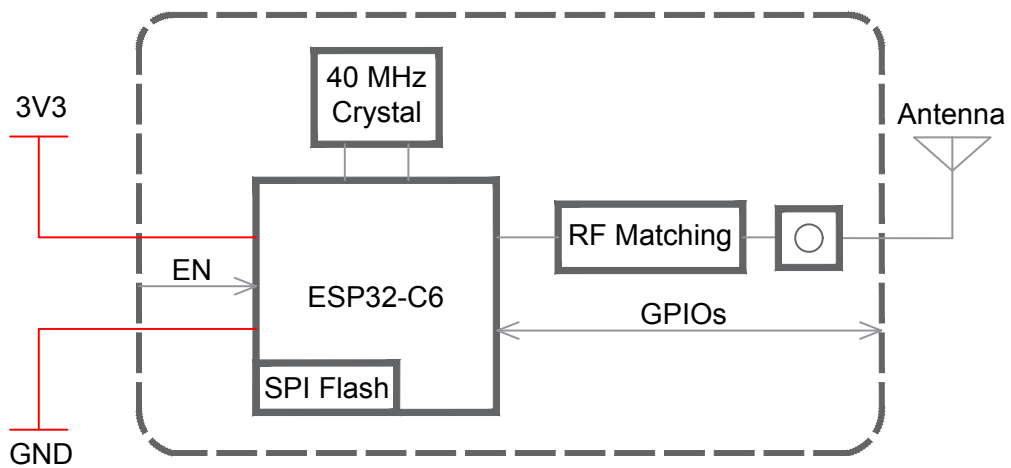

Figure 2: ESP32-C6-MINI-1U Block Diagram

3 Pin Definitions

3.1 Pin Layout

The pin diagram below shows the approximate location of pins on the module. For the actual diagram drawn to scale, please refer to Figure 8.1 *Physical Dimensions*.

The pin diagram is applicable for ESP32-C6-MINI-1 and ESP32-C6-MINI-1U, but the latter has no keepout zone.

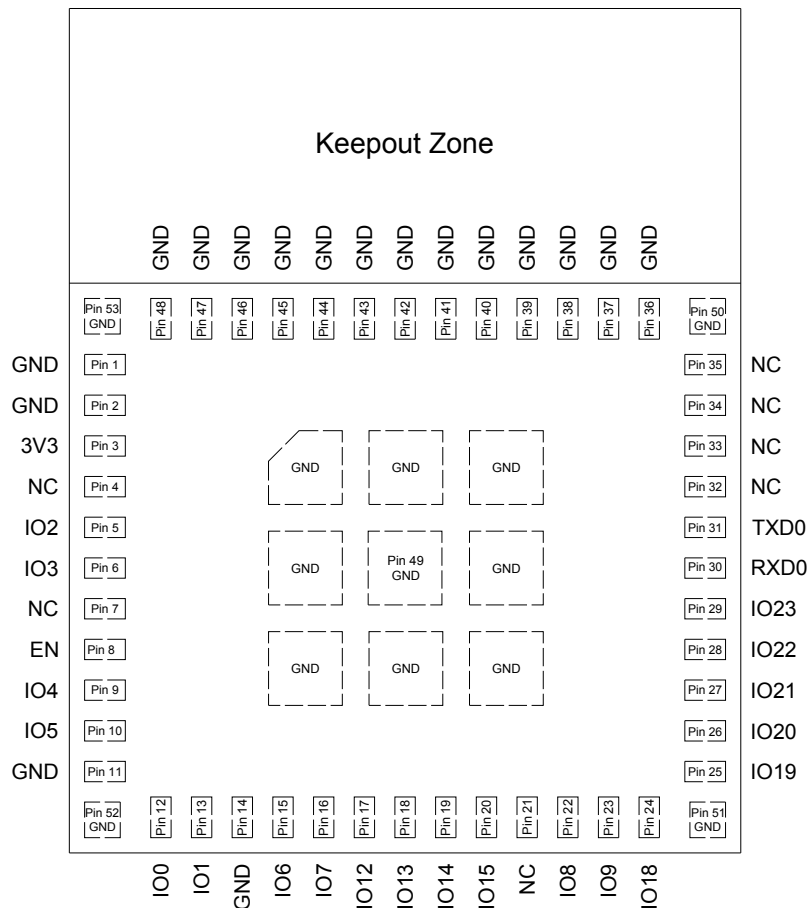

Figure 3: Pin Layout (Top View)

3.2 Pin Description

The module has 53 pins. See pin definitions in Table 3 *Pin Description*.

For peripheral pin configurations, please refer to [ESP32-C6 Series Datasheet](#).

Table 3: Pin Definitions

Name	No.	Type ¹	Function
GND	1, 2, 11, 14, 36~53	P	Ground
3V3	3	P	Power supply

Cont'd on next page

Table 3 – cont'd from previous page

Name	No.	Type ¹	Function
NC	4	—	NC
IO2	5	I/O/T	GPIO2, LP_GPIO2, LP_UART_RTSN, ADC1_CH2, FSPIQ
IO3	6	I/O/T	GPIO3, LP_GPIO3, LP_UART_CTSN, ADC1_CH3
NC	7	—	NC
EN	8	I	High: on, enables the chip. Low: off, the chip powers off. Note: Do not leave the EN pin floating.
IO4	9	I/O/T	MTMS, GPIO4, LP_GPIO4, LP_UART_RXD, ADC1_CH4, FSPIHD
IO5	10	I/O/T	MTDI, GPIO5, LP_GPIO5, LP_UART_TXD, ADC1_CH5, FSPIWP
IO0	12	I/O/T	GPIO0, XTAL_32K_P, LP_GPIO0, LP_UART_DTRN, ADC1_CH0
IO1	13	I/O/T	GPIO1, XTAL_32K_N, LP_GPIO1, LP_UART_DSRN, ADC1_CH1
IO6	15	I/O/T	MTCK, GPIO6, LP_GPIO6, LP_I2C_SDA, ADC1_CH6, FSPICLK
IO7	16	I/O/T	MTDO, GPIO7, LP_GPIO7, LP_I2C_SCL, FSPID
IO12	17	I/O/T	GPIO12, USB_D-
IO13	18	I/O/T	GPIO13, USB_D+
IO14	19	I/O/T	GPIO14
IO15	20	I/O/T	GPIO15
NC	21	—	NC
IO8	22	I/O/T	GPIO8
IO9	23	I/O/T	GPIO9
IO18	24	I/O/T	GPIO18, SDIO_CMD, FSPICS2
IO19	25	I/O/T	GPIO19, SDIO_CLK, FSPICS3
IO20	26	I/O/T	GPIO20, SDIO_DATA0, FSPICS4
IO21	27	I/O/T	GPIO21, SDIO_DATA1, FSPICS5
IO22	28	I/O/T	GPIO22, SDIO_DATA2
IO23	29	I/O/T	GPIO23, SDIO_DATA3
RXD0	30	I/O/T	U0RXD, GPIO17, FSPICS1
TXD0	31	I/O/T	U0TXD, GPIO16, FSPICS0
NC	32	—	NC
NC	33	—	NC
NC	34	—	NC
NC	35	—	NC

¹ P: power supply; I: input; O: output; T: high impedance.

3.3 Strapping Pins

Note:

The content below is excerpted from [ESP32-C6 Series Datasheet](#) > Section *Strapping Pins*. For the strapping pin mapping between the chip and modules, please refer to Chapter 6 *Module Schematics*.

At each startup or reset, a chip requires some initial configuration parameters, such as in which boot mode to load the chip, etc. These parameters are passed over via the strapping pins. After reset, the strapping pins

operate as regular IO pins.

The parameters controlled by the given strapping pins at chip reset are as follows:

- **SDIO sampling and driving clock edge** – MTMS and MTDI
- **Chip boot mode** – GPIO8 and GPIO9
- **ROM code printing to UART** – GPIO8
- **JTAG signal source** – GPIO15

GPIO9 is connected to the chip's internal weak pull-up resistor at chip reset. This resistor determines the default bit value of GPIO9. Also, the resistor determines the bit value if GPIO9 is connected to an external high-impedance circuit.

Table 4: Default Configuration of Strapping Pins

Strapping Pin	Default Configuration	Bit Value
MTMS	Floating	–
MTDI	Floating	–
GPIO8	Floating	–
GPIO9	Pull-up	1
GPIO15	Floating	–

To change the bit values, the strapping pins should be connected to external pull-down/pull-up resistances. If the ESP32-C6 is used as a device by a host MCU, the strapping pin voltage levels can also be controlled by the host MCU.

All strapping pins have latches. At system reset, the latches sample the bit values of their respective strapping pins and store them until the chip is powered down or shut down. The states of latches cannot be changed in any other way. It makes the strapping pin values available during the entire chip operation, and the pins are freed up to be used as regular IO pins after reset.

Regarding the timing requirements for the strapping pins, there are such parameters as *setup time* and *hold time*. For more information, see Table 5 and Figure 4.

Table 5: Description of Timing Parameters for the Strapping Pins

Parameter	Description	Min (ms)
t_{SU}	<i>Setup time</i> is the time reserved for the power rails to stabilize before the CHIP_PU pin is pulled high to activate the chip.	0
t_H	<i>Hold time</i> is the time reserved for the chip to read the strapping pin values after CHIP_PU is already high and before these pins start operating as regular IO pins.	3

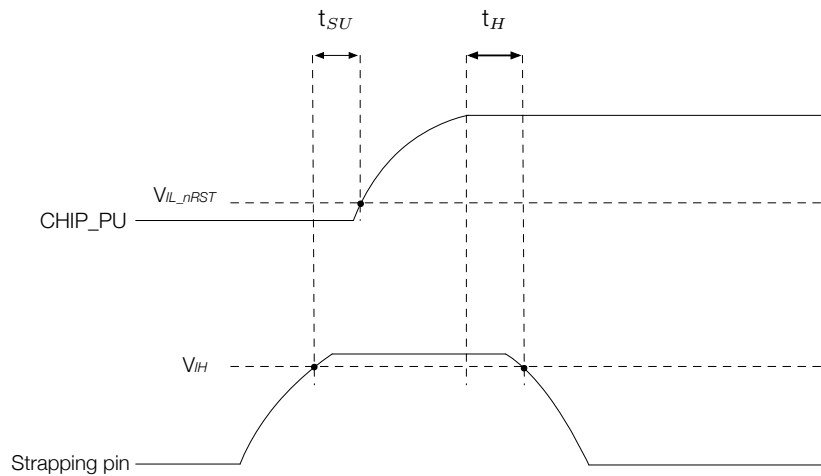

Figure 4: Visualization of Timing Parameters for the Strapping Pins

3.3.1 SDIO Sampling and Driving Clock Edge Control

The strapping pin MTMS and MTDI can be used to decide on which clock edge to sample signals and drive output lines. See Table 6 SDIO Input Sampling Edge/Output Driving Edge Control.

Table 6: SDIO Input Sampling Edge/Output Driving Edge Control

MTMS	MTDI	Edge behavior
– (Floating)	– (Floating)	Default Configuration
0	0	Falling edge sampling, falling edge output
0	1	Falling edge sampling, rising edge output
1	0	Rising edge sampling, falling edge output
1	1	Rising edge sampling, rising edge output

3.3.2 Chip Boot Mode Control

GPIO8 and GPIO9 control the boot mode after the reset is released. See Table 7 Boot Mode Control Boot Mode Control.

Table 7: Boot Mode Control

Boot Mode	GPIO8	GPIO9
Default Configuration	– (Floating)	1 (Pull-up)
SPI Boot (default)	Any value	1
Download Boot	1	0
Invalid combination ¹	0	0

¹ This combination triggers unexpected behavior and should be avoided.

3.3.3 ROM Messages Printing Control

During boot process the messages by the ROM code can be printed to:

- **USB Serial/JTAG controller.** For this, EFUSE_DIS_USB_SERIAL_JTAG_ROM_PRINT should be 0 and USB Serial/JTAG controller should be enabled.
- **UART0.** For this, set EFUSE_DIS_USB_SERIAL_JTAG_ROM_PRINT to 1. In this case, EFUSE_UART_PRINT_CONTROL and GPIO8 control ROM messages printing as shown in Table 8 ROM Messages Printing Control.

Table 8: ROM Messages Printing Control

eFuse ¹	GPIO8	ROM Code Printing
0	Ignored	Always enabled
1	0	Enabled
	1	Disabled
2	0	Disabled
	1	Enabled
3	Ignored	Always disabled

¹ eFuse: EFUSE_UART_PRINT_CONTROL

3.3.4 JTAG Signal Source Control

The strapping pin GPIO15 can be used to control the source of JTAG signals during the early boot process. This pin does not have any internal pull resistors and the strapping value must be controlled by the external circuit that cannot be in a high impedance state.

As Table 9 shows, GPIO15 is used in combination with EFUSE_DIS_PAD_JTAG, EFUSE_DIS_USB_JTAG, and EFUSE_JTAG_SEL_ENABLE.

Table 9: JTAG Signal Source Control

eFuse 1 ^a	eFuse 2 ^b	eFuse 3 ^c	GPIO15	JTAG Signal Source
0	0	0	Ignored	USB Serial/JTAG Controller
		1	0	JTAG pins MTDI, MTCK, MTMS, and MTDO
			1	USB Serial/JTAG Controller
0	1	Ignored	Ignored	JTAG pins MTDI, MTCK, MTMS, and MTDO
1	0	Ignored	Ignored	USB Serial/JTAG Controller
1	1	Ignored	Ignored	JTAG is disabled

^a eFuse 1: EFUSE_DIS_PAD_JTAG

^b eFuse 2: EFUSE_DIS_USB_JTAG

^c eFuse 3: EFUSE_JTAG_SEL_ENABLE

4 Electrical Characteristics

The values presented in this section are preliminary and may change with the final release of this datasheet.

4.1 Absolute Maximum Ratings

Stresses above those listed in Table 10 *Absolute Maximum Ratings* may cause permanent damage to the device. These are stress ratings only and functional operation of the device at these or any other conditions beyond those indicated under Table 11 *Recommended Operating Conditions* is not implied. Exposure to absolute-maximum-rated conditions for extended periods may affect device reliability.

Table 10: Absolute Maximum Ratings

Symbol	Parameter	Min	Max	Unit
VDD33	Power supply voltage	-0.3	3.6	V
T _{STORE}	Storage temperature	-40	105	°C

4.2 Recommended Operating Conditions

Table 11: Recommended Operating Conditions

Symbol	Parameter	Min	Typ	Max	Unit
VDD33	Power supply voltage	3.0	3.3	3.6	V
I _{VDD}	Current delivered by external power supply	0.5	—	—	A
T _A	Operating ambient temperature	85 °C version	-40	85	°C
		105 °C version		105	

4.3 DC Characteristics (3.3 V, 25 °C)

Table 12: DC Characteristics (3.3 V, 25 °C)

Symbol	Parameter	Min	Typ	Max	Unit
C _{IN}	Pin capacitance	—	2	—	pF
V _{IH}	High-level input voltage	0.75 × VDD ¹	—	VDD ¹ + 0.3	V
V _{IL}	Low-level input voltage	-0.3	—	0.25 × VDD ¹	V
I _{IH}	High-level input current	—	—	50	nA
I _{IL}	Low-level input current	—	—	50	nA
V _{OH} ²	High-level output voltage	0.8 × VDD ¹	—	—	V
V _{OL} ²	Low-level output voltage	—	—	0.1 × VDD ¹	V
I _{OH}	High-level source current (VDD ¹ = 3.3 V, V _{OH} >= 2.64 V, PAD_DRIVER = 3)	—	40	—	mA
I _{OL}	Low-level sink current (VDD ¹ = 3.3 V, V _{OL} = 0.495 V, PAD_DRIVER = 3)	—	28	—	mA
R _{PU}	Pull-up resistor	—	45	—	kΩ

R_{PD}	Pull-down resistor	—	45	—	$k\Omega$
V_{IH_nRST}	Chip reset release voltage	$0.75 \times VDD^1$	—	$VDD^1 + 0.3$	V
V_{IL_nRST}	Chip reset voltage	-0.3	—	$0.25 \times VDD^1$	V

¹ VDD is the I/O voltage for pins of a particular power domain.

² V_{OH} and V_{OL} are measured using high-impedance load.

4.4 Current Consumption Characteristics

4.4.1 Current Consumption in Active Mode

The current consumption measurements are taken with a 3.3 V supply at 25 °C ambient temperature.

TX current consumption is rated at a 100% duty cycle.

RX current consumption is rated when the peripherals are disabled and the CPU idle.

Table 13: Current Consumption for Wi-Fi (2.4 GHz) in Active Mode

Work Mode	RF Condition	Description	Peak (mA)
Active (RF working)	TX	802.11b, 1 Mbps, DSSS @ 20.5 dBm	382
		802.11g, 54 Mbps, OFDM @ 19.0 dBm	316
		802.11n, HT20, MCS7 @ 18.0 dBm	295
		802.11n, HT40, MCS7 @ 17.5 dBm	280
		802.11ax, MCS9 @ 15.5 dBm	251
	RX	802.11b/g/n, HT20	78
		802.11n, HT40	82
		802.11ax, HE20	78

Table 14: Current Consumption for Bluetooth LE in Active Mode

Work Mode	RF Condition	Description	Peak (mA)
Active (RF working)	TX	Bluetooth LE @ 20.0 dBm	322
		Bluetooth LE @ 9.0 dBm	190
		Bluetooth LE @ 0 dBm	130
		Bluetooth LE @ -24.0 dBm	90
	RX	Bluetooth LE	73

Table 15: Current Consumption for 802.15.4 in Active Mode

Work Mode	RF Condition	Description	Peak (mA)
Active (RF working)	TX	802.15.4 @ 20.0 dBm	316
		802.15.4 @ 12.0 dBm	190
		802.15.4 @ 0 dBm	120
		802.15.4 @ -24.0 dBm	84
	RX	802.15.4	73

Note:

The content below is excerpted from *Section Current Consumption in Other Modes* in [ESP32-C6 Series Datasheet](#).

4.4.2 Current Consumption in Other Modes

Table 16: Current Consumption in Modem-sleep Mode

Mode	CPU Frequency (MHz)	Description	Typ (mA)	
			All Peripherals Clocks Disabled	All Peripherals Clocks Enabled ¹
Modem-sleep ^{2,3}	160	CPU is running	27	38
		CPU is idle	17	28
	80	CPU is running	19	30
		CPU is idle	14	25

¹ In practice, the current consumption might be different depending on which peripherals are enabled.

² In Modem-sleep mode, Wi-Fi is clock gated.

³ In Modem-sleep mode, the consumption might be higher when accessing flash.

Table 17: Current Consumption in Low-Power Modes

Mode	Description	Typ (μ A)
Light-sleep	CPU and wireless communication modules are powered down, peripheral clocks are disabled, and all GPIOs are high-impedance	180
	CPU, wireless communication modules and peripherals are powered down, and all GPIOs are high-impedance	35
Deep-sleep	RTC timer and LP memory are powered on	7
Power off	CHIP_PU is set to low level, the chip is powered off	1

5 RF Characteristics

This section contains tables with RF characteristics of the Espressif product.

The RF data is measured at the antenna port, where RF cable is connected, including the front-end loss. The external antennas used for the tests on the modules with external antenna connectors have an impedance of 50 Ω .

Devices should operate in the center frequency range allocated by regional regulatory authorities. The target center frequency range and the target transmit power are configurable by software. See [ESP RF Test Tool and Test Guide](#) for instructions.

Unless otherwise stated, the RF tests are conducted with a 3.3 V ($\pm 5\%$) supply at 25 °C ambient temperature.

5.1 Wi-Fi Radio (2.4 GHz/5 GHz)

Table 18: Wi-Fi RF Characteristics

Name	Description
Center frequency range of operating channel	2412 ~ 2484 MHz
Wi-Fi wireless standard	IEEE 802.11b/g/n/ax

5.1.1 Wi-Fi RF Transmitter (TX) Characteristics

Table 19: TX Power with Spectral Mask and EVM Meeting 802.11 Standards

Rate	Min (dBm)	Typ (dBm)	Max (dBm)
802.11b, 1 Mbps, DSSS	—	20.5	—
802.11b, 11 Mbps, CCK	—	20.5	—
802.11g, 6 Mbps, OFDM	—	20.0	—
802.11g, 54 Mbps, OFDM	—	19.0	—
802.11n, HT20, MCS0	—	19.0	—
802.11n, HT20, MCS7	—	18.0	—
802.11n, HT40, MCS0	—	18.5	—
802.11n, HT40, MCS7	—	17.5	—
802.11ax, HE20, MCS0	—	19.0	—
802.11ax, HE20, MCS9	—	15.5	—

Table 20: TX EVM Test¹

Rate	Min (dB)	Typ (dB)	Limit (dB)
802.11b, 1 Mbps, DSSS	—	-25.0	-10.0
802.11b, 11 Mbps, CCK	—	-25.0	-10.0

Cont'd on next page

Table 20 – cont'd from previous page

Rate	Min (dB)	Typ (dB)	Limit (dB)
802.11g, 6 Mbps, OFDM	—	-24.0	-5.0
802.11g, 54 Mbps, OFDM	—	-28.0	-25.0
802.11n, HT20, MCS0	—	-27.5	-5.0
802.11n, HT20, MCS7	—	-30.0	-27.0
802.11n, HT40, MCS0	—	-27.0	-5.0
802.11n, HT40, MCS7	—	-29.5	-27.0
802.11ax, HE20, MCS0	—	-27.0	-5.0
802.11ax, HE20, MCS9	—	-34.0	-32.0

¹ EVM is measured at the corresponding typical TX power provided in Table 19 *Wi-Fi RF Transmitter (TX) Characteristics* above.

5.1.2 Wi-Fi RF Receiver (RX) Characteristics

For RX tests, the PER (packet error rate) limit is 8% for 802.11b, and 10% for 802.11g/n/ax.

Table 21: RX Sensitivity

Rate	Min (dBm)	Typ (dBm)	Max (dBm)
802.11b, 1 Mbps, DSSS	—	-99.2	—
802.11b, 2 Mbps, DSSS	—	-96.8	—
802.11b, 5.5 Mbps, CCK	—	-93.6	—
802.11b, 11 Mbps, CCK	—	-90.0	—
802.11g, 6 Mbps, OFDM	—	-94.0	—
802.11g, 9 Mbps, OFDM	—	-93.0	—
802.11g, 12 Mbps, OFDM	—	-92.4	—
802.11g, 18 Mbps, OFDM	—	-90.0	—
802.11g, 24 Mbps, OFDM	—	-86.8	—
802.11g, 36 Mbps, OFDM	—	-83.0	—
802.11g, 48 Mbps, OFDM	—	-78.8	—
802.11g, 54 Mbps, OFDM	—	-77.6	—
802.11n, HT20, MCS0	—	-93.6	—
802.11n, HT20, MCS1	—	-92.0	—
802.11n, HT20, MCS2	—	-89.4	—
802.11n, HT20, MCS3	—	-86.0	—
802.11n, HT20, MCS4	—	-82.8	—
802.11n, HT20, MCS5	—	-78.6	—
802.11n, HT20, MCS6	—	-77.0	—
802.11n, HT20, MCS7	—	-75.4	—
802.11n, HT40, MCS0	—	-91.0	—
802.11n, HT40, MCS1	—	-89.6	—

Cont'd on next page

Table 21 – cont'd from previous page

Rate	Min (dBm)	Typ (dBm)	Max (dBm)
802.11n, HT40, MCS2	—	-87.0	—
802.11n, HT40, MCS3	—	-83.4	—
802.11n, HT40, MCS4	—	-80.4	—
802.11n, HT40, MCS5	—	-76.2	—
802.11n, HT40, MCS6	—	-74.6	—
802.11n, HT40, MCS7	—	-73.2	—
802.11ax, HE20, MCS0	—	-93.8	—
802.11ax, HE20, MCS1	—	-91.0	—
802.11ax, HE20, MCS2	—	-88.0	—
802.11ax, HE20, MCS3	—	-85.6	—
802.11ax, HE20, MCS4	—	-82.0	—
802.11ax, HE20, MCS5	—	-78.0	—
802.11ax, HE20, MCS6	—	-76.6	—
802.11ax, HE20, MCS7	—	-74.4	—
802.11ax, HE20, MCS8	—	-70.8	—
802.11ax, HE20, MCS9	—	-68.6	—

Table 22: Maximum RX Level

Rate	Min (dBm)	Typ (dBm)	Max (dBm)
802.11b, 1 Mbps, DSSS	—	5	—
802.11b, 11 Mbps, CCK	—	5	—
802.11g, 6 Mbps, OFDM	—	5	—
802.11g, 54 Mbps, OFDM	—	0	—
802.11n, HT20, MCS0	—	5	—
802.11n, HT20, MCS7	—	0	—
802.11n, HT40, MCS0	—	5	—
802.11n, HT40, MCS7	—	0	—
802.11ax, HE20, MCS0	—	5	—
802.11ax, HE20, MCS9	—	0	—

Table 23: RX Adjacent Channel Rejection

Rate	Min (dB)	Typ (dB)	Max (dB)
802.11b, 1 Mbps, DSSS	—	38	—
802.11b, 11 Mbps, CCK	—	38	—
802.11g, 6 Mbps, OFDM	—	31	—
802.11g, 54 Mbps, OFDM	—	20	—

Cont'd on next page

Table 23 – cont'd from previous page

Rate	Min (dB)	Typ (dB)	Max (dB)
802.11n, HT20, MCS0	—	31	—
802.11n, HT20, MCS7	—	16	—
802.11n, HT40, MCS0	—	28	—
802.11n, HT40, MCS7	—	10	—
802.11ax, HE20, MCS0	—	25	—
802.11ax, HE20, MCS9	—	2	—

5.2 Bluetooth 5 (LE) Radio

Table 24: Bluetooth LE RF Characteristics

Name	Description
Center frequency range of operating channel	2402 ~ 2480 MHz
RF transmit power range	-24.0 ~ 20.0 dBm

5.2.1 Bluetooth LE RF Transmitter (TX) Characteristics

Table 25: Bluetooth LE - Transmitter Characteristics - 1 Mbps

Parameter	Description	Min	Typ	Max	Unit
Carrier frequency offset and drift	Max. $ f_n _{n=0, 1, 2, 3, \dots, k}$	—	1.3	—	kHz
	Max. $ f_0 - f_n _{n=2, 3, 4, \dots, k}$	—	1.5	—	kHz
	Max. $ f_n - f_{n-5} _{n=6, 7, 8, \dots, k}$	—	0.9	—	kHz
	$ f_1 - f_0 $	—	0.6	—	kHz
Modulation characteristics	$\Delta F1_{avg}$	—	249.9	—	kHz
	Min. $\Delta F2_{max}$ (for at least 99.9% of all $\Delta F2_{max}$)	—	212.1	—	kHz
	$\Delta F2_{avg}/\Delta F1_{avg}$	—	0.88	—	—
In-band emissions	± 2 MHz offset	—	-29	—	dBm
	± 3 MHz offset	—	-36	—	dBm
	$> \pm 3$ MHz offset	—	-39	—	dBm

Table 26: Bluetooth LE - Transmitter Characteristics - 2 Mbps

Parameter	Description	Min	Typ	Max	Unit
Carrier frequency offset and drift	Max. $ f_n _{n=0, 1, 2, 3, \dots, k}$	—	2.2	—	kHz
	Max. $ f_0 - f_n _{n=2, 3, 4, \dots, k}$	—	1.1	—	kHz
	Max. $ f_n - f_{n-5} _{n=6, 7, 8, \dots, k}$	—	1.1	—	kHz
	$ f_1 - f_0 $	—	0.5	—	kHz
Modulation characteristics	$\Delta F1_{avg}$	—	499.4	—	kHz

Cont'd on next page

Table 26 – cont'd from previous page

Parameter	Description	Min	Typ	Max	Unit
	Min. $\Delta F2_{\max}$ (for at least 99.9% of all $\Delta F2_{\max}$)	—	443.5	—	kHz
	$\Delta F2_{\text{avg}}/\Delta F1_{\text{avg}}$	—	0.95	—	—
In-band emissions	± 4 MHz offset	—	-40	—	dBm
	± 5 MHz offset	—	-41	—	dBm
	$> \pm 5$ MHz offset	—	-42	—	dBm

Table 27: Bluetooth LE - Transmitter Characteristics - 125 Kbps

Parameter	Description	Min	Typ	Max	Unit
Carrier frequency offset and drift	Max. $ f_n _{n=0, 1, 2, 3, \dots, k}$	—	0.7	—	kHz
	Max. $ f_0 - f_n _{n=1, 2, 3, \dots, k}$	—	0.3	—	kHz
	$ f_0 - f_3 $	—	0.1	—	kHz
	Max. $ f_n - f_{n-3} _{n=7, 8, 9, \dots, k}$	—	0.4	—	kHz
Modulation characteristics	$\Delta F1_{\text{avg}}$	—	250.0	—	kHz
	Min. $\Delta F1_{\max}$ (for at least 99.9% of all $\Delta F1_{\max}$)	—	238.0	—	kHz
In-band emissions	± 2 MHz offset	—	-29	—	dBm
	± 3 MHz offset	—	-36	—	dBm
	$> \pm 3$ MHz offset	—	-39	—	dBm

Table 28: Bluetooth LE - Transmitter Characteristics - 500 Kbps

Parameter	Description	Min	Typ	Max	Unit
Carrier frequency offset and drift	Max. $ f_n _{n=0, 1, 2, 3, \dots, k}$	—	0.5	—	kHz
	Max. $ f_0 - f_n _{n=1, 2, 3, \dots, k}$	—	0.3	—	kHz
	$ f_0 - f_3 $	—	0.1	—	kHz
	Max. $ f_n - f_{n-3} _{n=7, 8, 9, \dots, k}$	—	0.4	—	kHz
Modulation characteristics	$\Delta F2_{\text{avg}}$	—	230.7	—	kHz
	Min. $\Delta F2_{\max}$ (for at least 99.9% of all $\Delta F2_{\max}$)	—	217.6	—	kHz
In-band emissions	± 2 MHz offset	—	-28	—	dBm
	± 3 MHz offset	—	-36	—	dBm
	$> \pm 3$ MHz offset	—	-39	—	dBm

5.2.2 Bluetooth LE RF Receiver (RX) Characteristics

Table 29: Bluetooth LE - Receiver Characteristics - 1 Mbps

Parameter	Description	Min	Typ	Max	Unit
Sensitivity @30.8% PER	—	—	-98.0	—	dBm
Maximum received signal @30.8% PER	—	—	8	—	dBm

Cont'd on next page

Table 29 – cont'd from previous page

Parameter		Description	Min	Typ	Max	Unit
C/I and receiver selectivity performance	Co-channel	$F = F_0$ MHz	—	7	—	dB
	Adjacent channel	$F = F_0 + 1$ MHz	—	4	—	dB
		$F = F_0 - 1$ MHz	—	3	—	dB
		$F = F_0 + 2$ MHz	—	-21	—	dB
		$F = F_0 - 2$ MHz	—	-22	—	dB
		$F = F_0 + 3$ MHz	—	-28	—	dB
		$F = F_0 - 3$ MHz	—	-36	—	dB
		$F \geq F_0 + 4$ MHz	—	-27	—	dB
		$F \leq F_0 - 4$ MHz	—	-36	—	dB
	Image frequency	—	—	-26	—	dB
Adjacent channel to image frequency	$F = F_{image} + 1$ MHz	—	-29	—	dB	
	$F = F_{image} - 1$ MHz	—	-28	—	dB	
Out-of-band blocking performance		30 MHz ~ 2000 MHz	—	-16	—	dBm
		2003 MHz ~ 2399 MHz	—	-24	—	dBm
		2484 MHz ~ 2997 MHz	—	-16	—	dBm
		3000 MHz ~ 12.75 GHz	—	-1	—	dBm
Intermodulation		—	—	-27	—	dBm

Table 30: Bluetooth LE - Receiver Characteristics - 2 Mbps

Parameter		Description	Min	Typ	Max	Unit
Sensitivity @30.8% PER		—	—	-95.0	—	dBm
Maximum received signal @30.8% PER		—	—	8	—	dBm
C/I and receiver selectivity performance	Co-channel	$F = F_0$ MHz	—	8	—	dB
	Adjacent channel	$F = F_0 + 2$ MHz	—	3	—	dB
		$F = F_0 - 2$ MHz	—	2	—	dB
		$F = F_0 + 4$ MHz	—	-23	—	dB
		$F = F_0 - 4$ MHz	—	-25	—	dB
		$F = F_0 + 6$ MHz	—	-31	—	dB
		$F = F_0 - 6$ MHz	—	-35	—	dB
		$F \geq F_0 + 8$ MHz	—	-36	—	dB
		$F \leq F_0 - 8$ MHz	—	-36	—	dB
	Image frequency	—	—	-23	—	dB
Adjacent channel to image frequency	$F = F_{image} + 2$ MHz	—	-30	—	dB	
	$F = F_{image} - 2$ MHz	—	3	—	dB	
Out-of-band blocking performance		30 MHz ~ 2000 MHz	—	-18	—	dBm
		2003 MHz ~ 2399 MHz	—	-28	—	dBm
		2484 MHz ~ 2997 MHz	—	-16	—	dBm
		3000 MHz ~ 12.75 GHz	—	-1	—	dBm
Intermodulation		—	—	-29	—	dBm

Table 31: Bluetooth LE - Receiver Characteristics - 125 Kbps

Parameter	Description	Min	Typ	Max	Unit	
Sensitivity @30.8% PER	—	—	-105.5	—	dBm	
Maximum received signal @30.8% PER	—	—	8	—	dBm	
C/I and receiver selectivity performance	Co-channel	$F = F_0$ MHz	—	2	—	dB
	Adjacent channel	$F = F_0 + 1$ MHz	—	-1	—	dB
		$F = F_0 - 1$ MHz	—	-3	—	dB
		$F = F_0 + 2$ MHz	—	-31	—	dB
		$F = F_0 - 2$ MHz	—	-27	—	dB
		$F = F_0 + 3$ MHz	—	-33	—	dB
		$F = F_0 - 3$ MHz	—	-42	—	dB
		$F \geq F_0 + 4$ MHz	—	-31	—	dB
		$F \leq F_0 - 4$ MHz	—	-48	—	dB
	Image frequency	—	—	-31	—	dB
Adjacent channel to image frequency	$F = F_{image} + 1$ MHz	—	-36	—	dB	
	$F = F_{image} - 1$ MHz	—	-33	—	dB	

Table 32: Bluetooth LE - Receiver Characteristics - 500 Kbps

Parameter	Description	Min	Typ	Max	Unit	
Sensitivity @30.8% PER	—	—	-101.5	—	dBm	
Maximum received signal @30.8% PER	—	—	8	—	dBm	
C/I and receiver selectivity performance	Co-channel	$F = F_0$ MHz	—	4	—	dB
	Adjacent channel	$F = F_0 + 1$ MHz	—	1	—	dB
		$F = F_0 - 1$ MHz	—	-1	—	dB
		$F = F_0 + 2$ MHz	—	-23	—	dB
		$F = F_0 - 2$ MHz	—	-24	—	dB
		$F = F_0 + 3$ MHz	—	-33	—	dB
		$F = F_0 - 3$ MHz	—	-41	—	dB
		$F \geq F_0 + 4$ MHz	—	-31	—	dB
		$F \leq F_0 - 4$ MHz	—	-41	—	dB
	Image frequency	—	—	-30	—	dB
Adjacent channel to image frequency	$F = F_{image} + 1$ MHz	—	-35	—	dB	
	$F = F_{image} - 1$ MHz	—	-27	—	dB	

5.3 802.15.4 Radio

Table 33: 802.15.4 RF Characteristics

Name	Description
Center frequency range of operating channel	2405 ~ 2480 MHz

¹ Zigbee in the 2.4 GHz range supports 16 channels at 5 MHz spacing from channel 11 to channel 26.

5.3.1 802.15.4 RF Transmitter (TX) Characteristics

Table 34: 802.15.4 Transmitter Characteristics - 250 Kbps

Parameter	Min	Typ	Max	Unit
RF transmit power range	-24.0	—	20.0	dBm
EVM	—	13%	—	—

5.3.2 802.15.4 RF Receiver (RX) Characteristics

Table 35: 802.15.4 Receiver Characteristics - 250 Kbps

Parameter	Description	Min	Typ	Max	Unit	
Sensitivity @1% PER	—	—	-104.0	—	dBm	
Maximum received signal @1% PER	—	—	8	—	dBm	
Relative jamming level	Adjacent channel	$F = F_0 + 5 \text{ MHz}$	—	27	—	dB
		$F = F_0 - 5 \text{ MHz}$	—	32	—	dB
	Alternate channel	$F = F_0 + 10 \text{ MHz}$	—	47	—	dB
		$F = F_0 - 10 \text{ MHz}$	—	50	—	dB

6 Module Schematics

This is the reference design of the module.

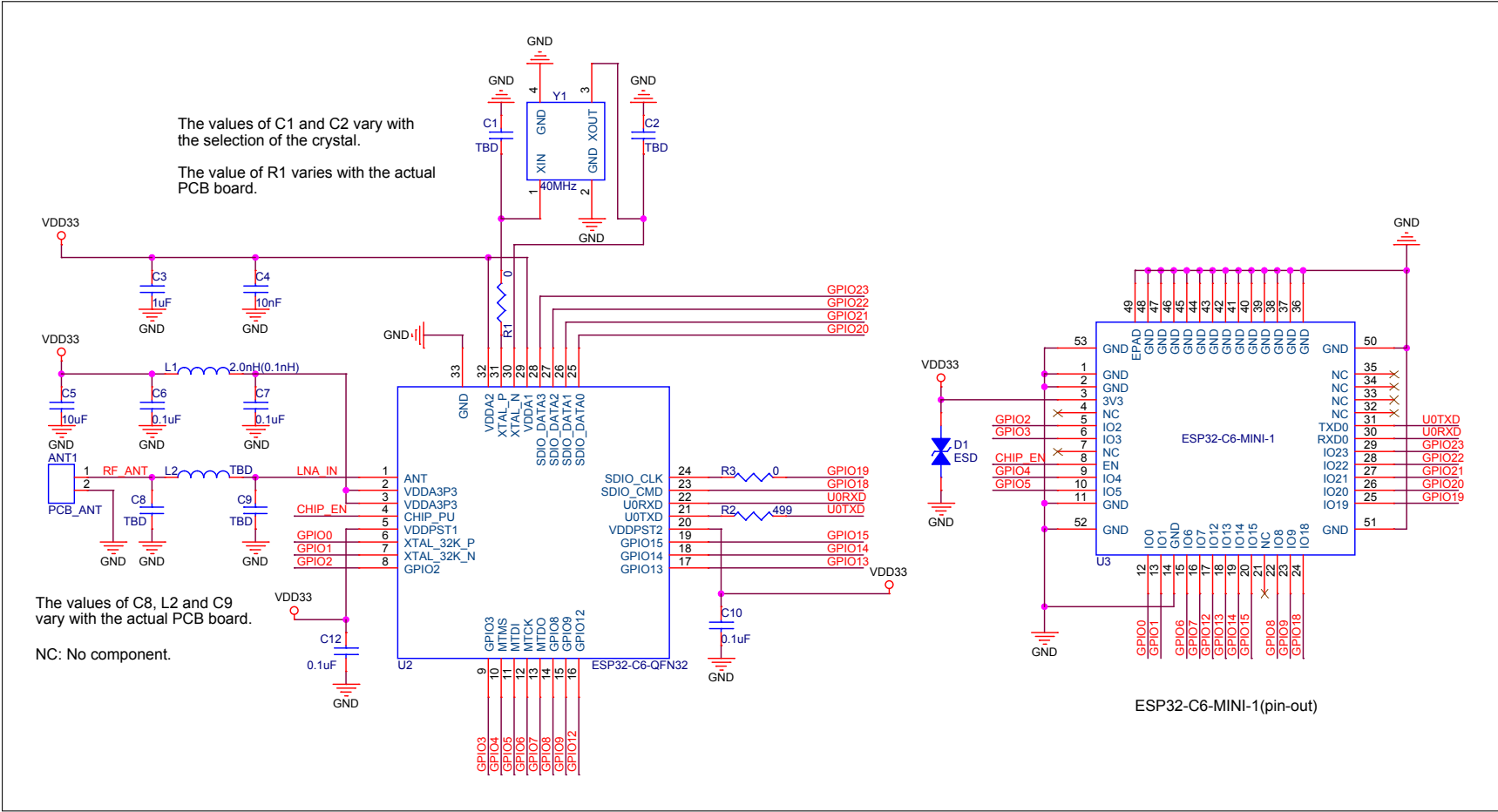

Figure 5: ESP32-C6-MINI-1 Schematics

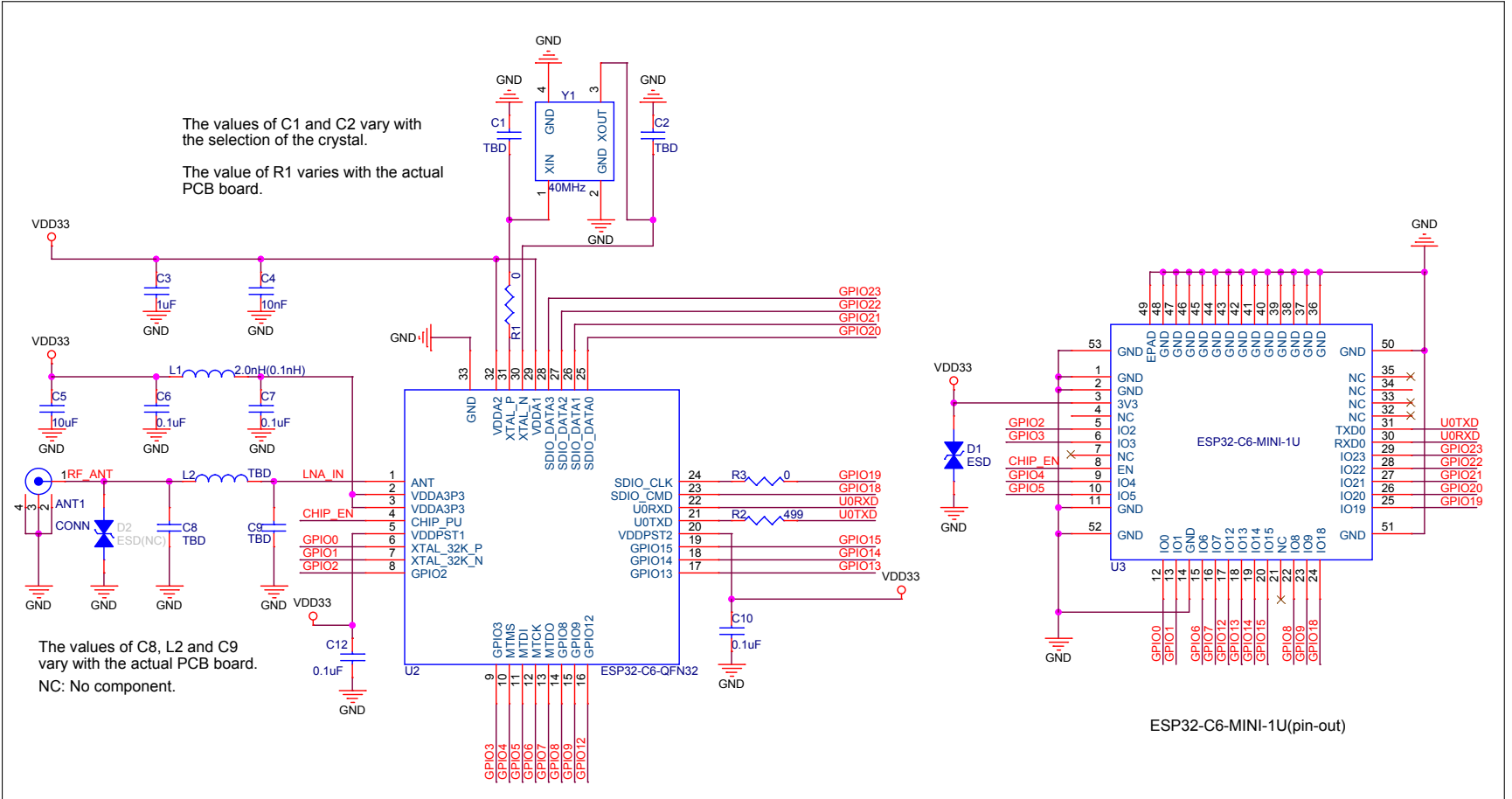

Figure 6: ESP32-C6-MINI-1U Schematics

7 Peripheral Schematics

This is the typical application circuit of the module connected with peripheral components (for example, power supply, antenna, reset button, JTAG interface, and UART interface).

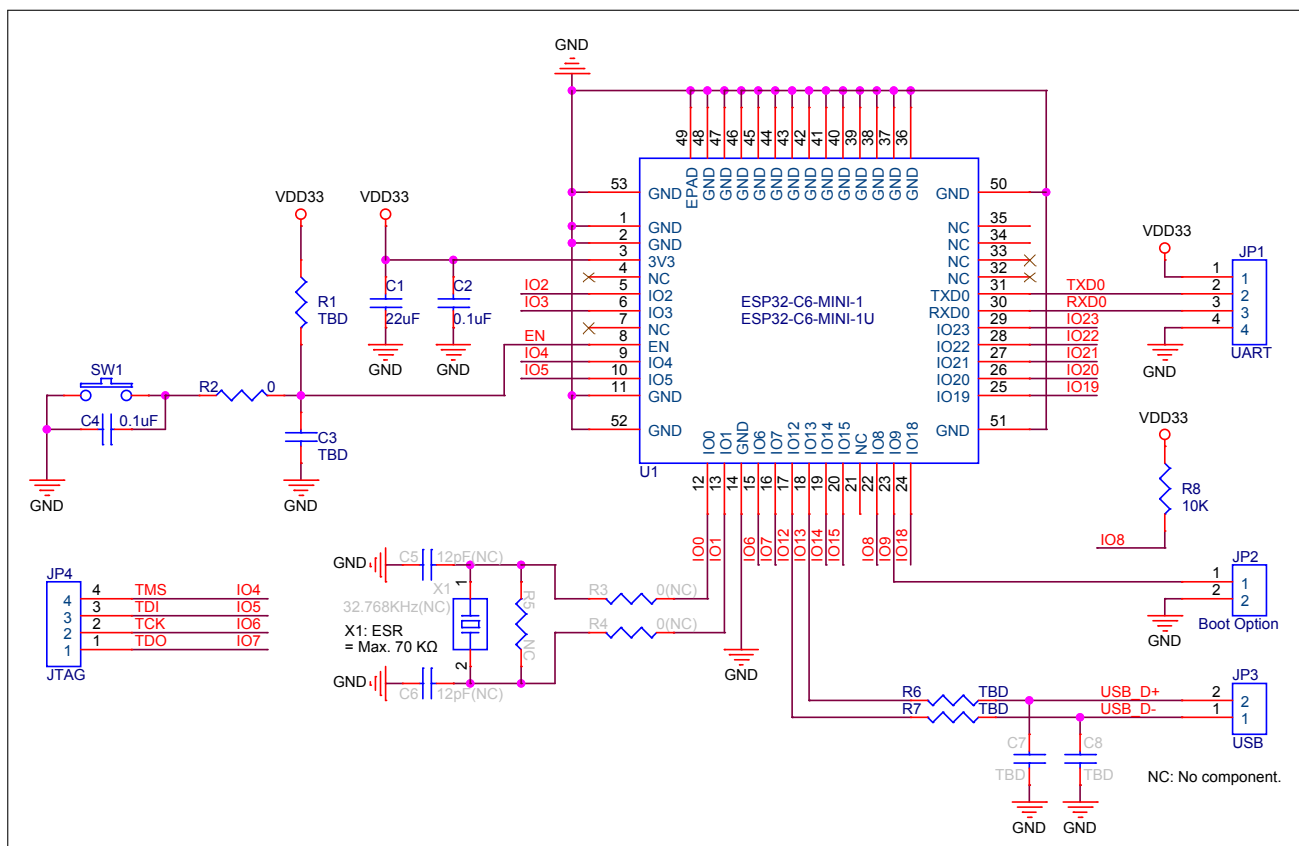

Figure 7: Peripheral Schematics

- Soldering the EPAD to the ground of the base board is not a must, however, it can optimize thermal performance. If you choose to solder it, please apply the correct amount of soldering paste. Too much soldering paste may increase the gap between the module and the baseboard. As a result, the adhesion between other pins and the baseboard may be poor.
- To ensure that the power supply to the ESP32-C6 chip is stable during power-up, it is advised to add an RC delay circuit at the EN pin. The recommended setting for the RC delay circuit is usually $R = 10 \text{ k}\Omega$ and $C = 1 \mu\text{F}$. However, specific parameters should be adjusted based on the power-up timing of the module and the power-up and reset sequence timing of the chip. For ESP32-C6's power-up and reset sequence timing diagram, please refer to [ESP32-C6 Series Datasheet](#) > Section *Power Supply*.

8 Physical Dimensions and PCB Land Pattern

8.1 Physical Dimensions

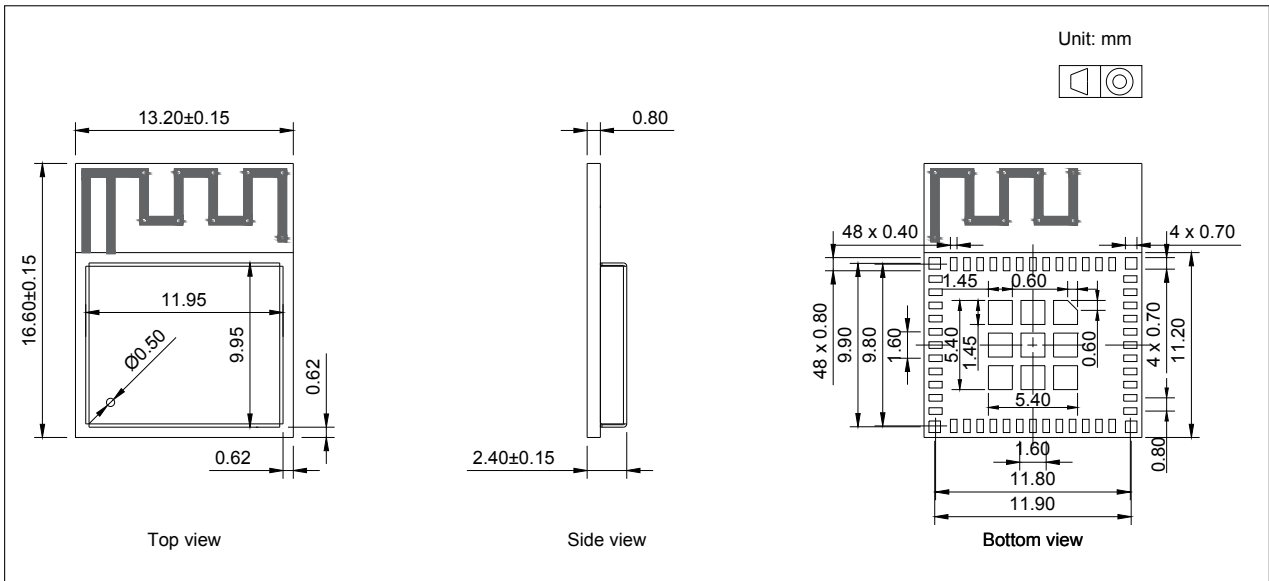

Figure 8: ESP32-C6-MINI-1 Physical Dimensions

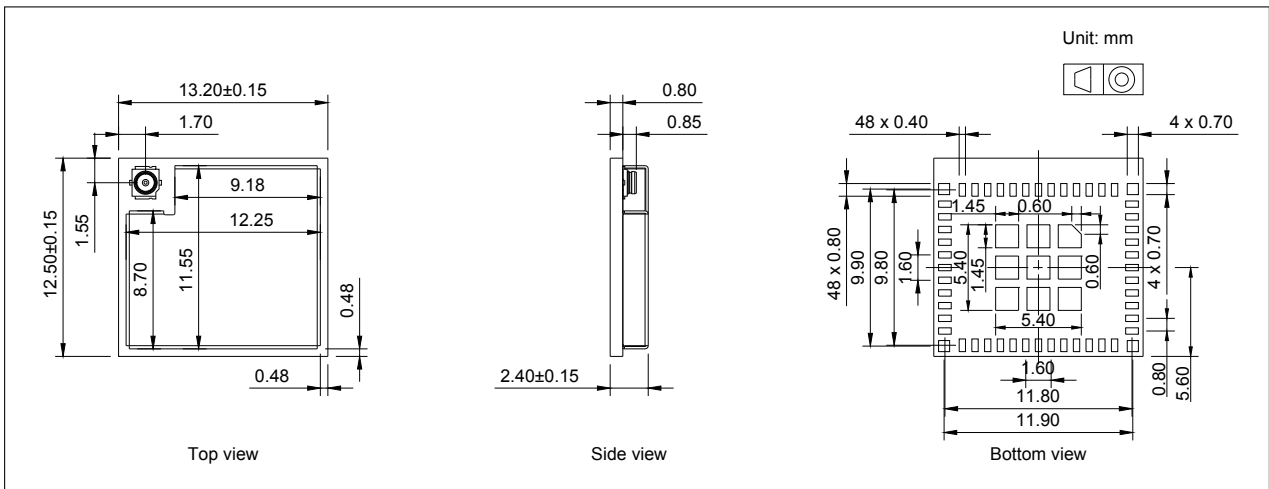

Figure 9: ESP32-C6-MINI-1U Physical Dimensions

Note:

For information about tape, reel, and product marking, please refer to [Espressif Module Packaging Information](#).

8.2 Recommended PCB Land Pattern

This section provides the following resources for your reference:

- Figures for recommended PCB land patterns with all the dimensions needed for PCB design. See Figure 10 *ESP32-C6-MINI-1 Recommended PCB Land Pattern* and Figure 11 *ESP32-C6-MINI-1U Recommended PCB Land Pattern*.
- Source files of recommended PCB land patterns to measure dimensions not covered in Figure 10. You can view the source files for [ESP32-C6-MINI-1](#) with [Autodesk Viewer](#).

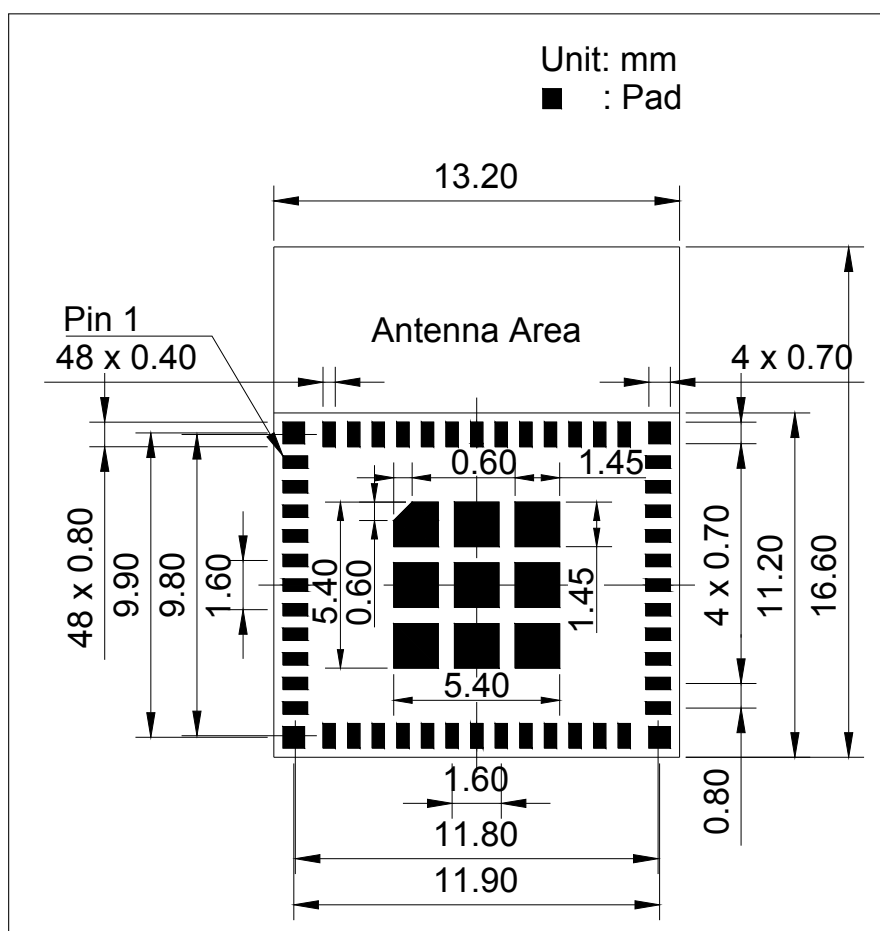

Figure 10: ESP32-C6-MINI-1 Recommended PCB Land Pattern

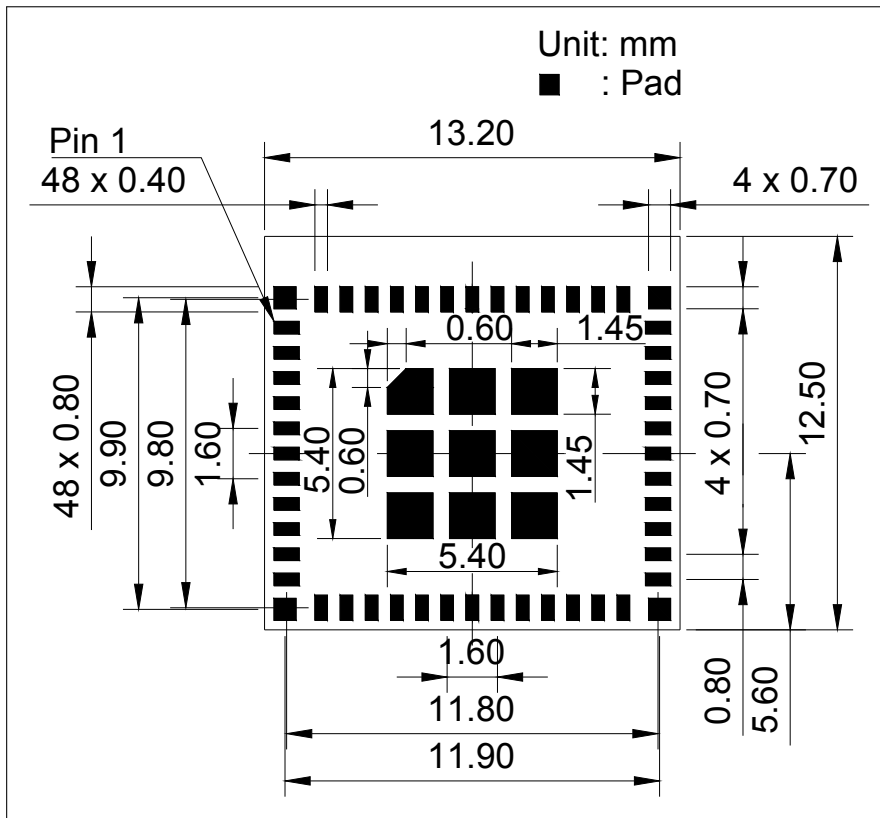

Figure 11: ESP32-C6-MINI-1U Recommended PCB Land Pattern

8.3 Dimensions of External Antenna Connector

ESP32-C6-MINI-1U uses the third generation external antenna connector as shown in Figure 12 *Dimensions of External Antenna Connector*. This connector is compatible with the following connectors:

- W.FL Series connector from Hirose
- MHF III connector from I-PEX
- AMMC connector from Amphenol

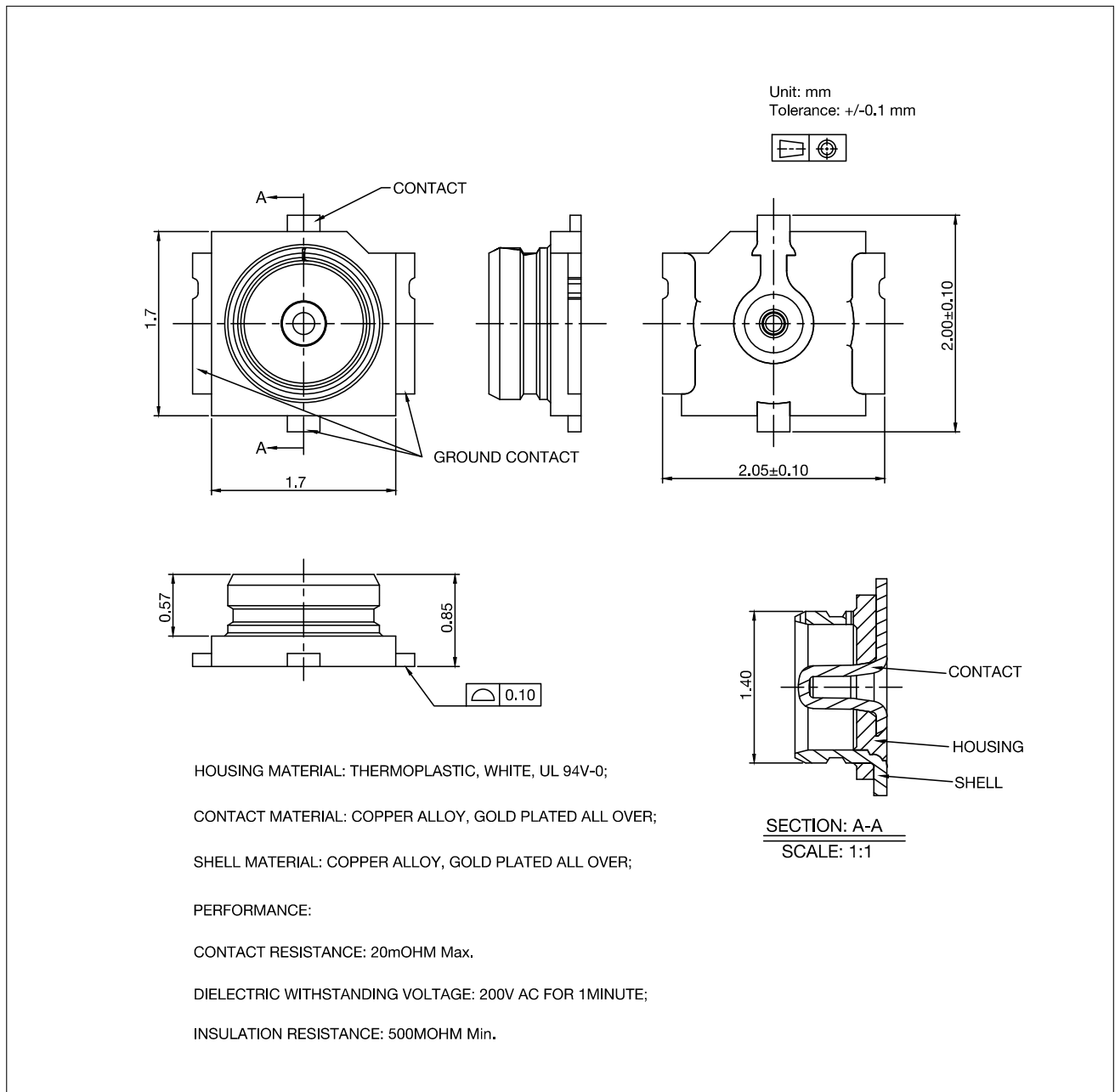

Figure 12: Dimensions of External Antenna Connector

9 Product Handling

9.1 Storage Conditions

The products sealed in moisture barrier bags (MBB) should be stored in a non-condensing atmospheric environment of $< 40\text{ }^{\circ}\text{C}$ and 90%RH. The module is rated at the moisture sensitivity level (MSL) of 3.

After unpacking, the module must be soldered within 168 hours with the factory conditions $25\pm 5\text{ }^{\circ}\text{C}$ and 60%RH. If the above conditions are not met, the module needs to be baked.

9.2 Electrostatic Discharge (ESD)

- Human body model (HBM): $\pm 2000\text{ V}$
- Charged-device model (CDM): $\pm 500\text{ V}$

9.3 Soldering Profile

9.3.1 Reflow Profile

Solder the module in a single reflow.

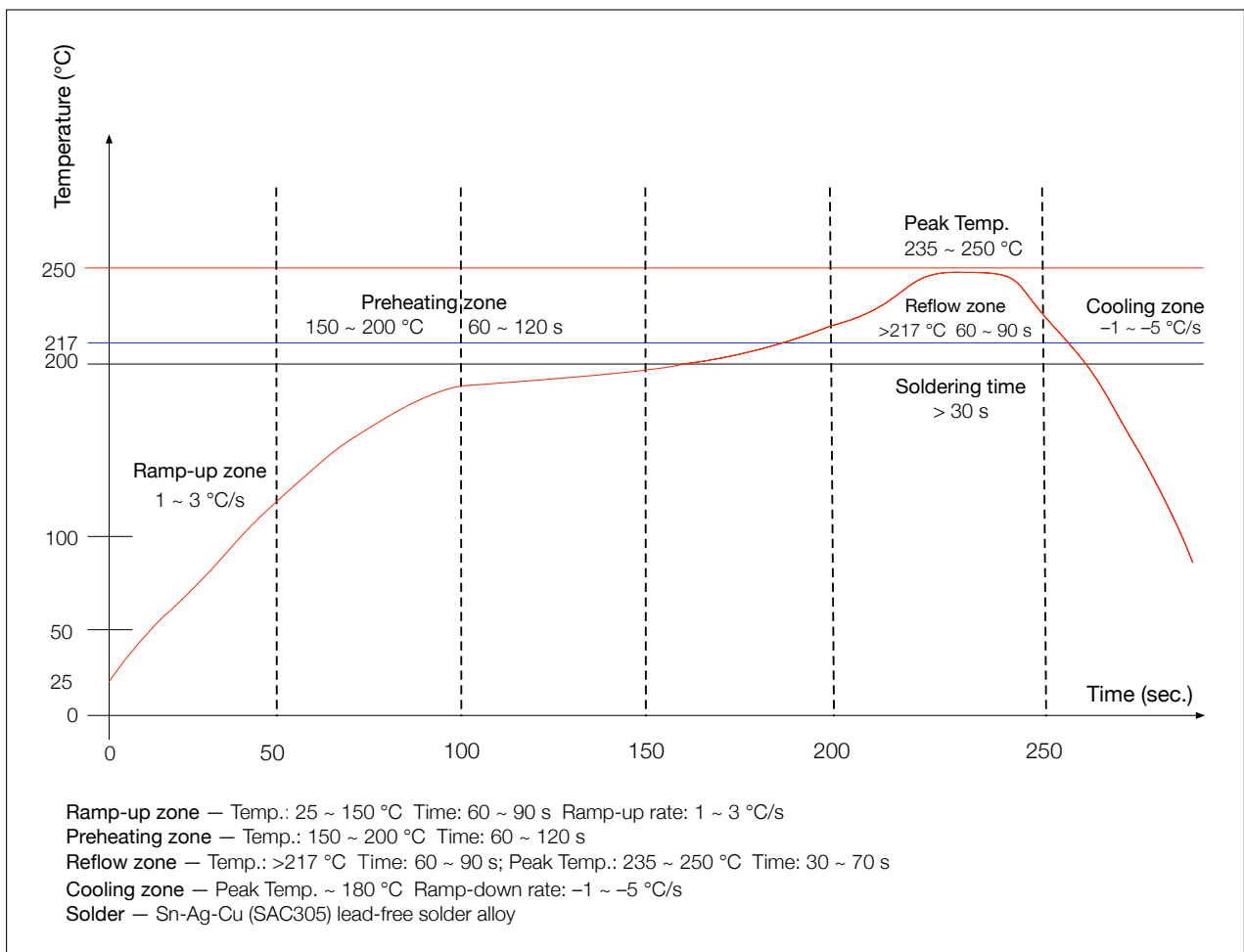

Figure 13: Reflow Profile

9.4 Ultrasonic Vibration

Avoid exposing Espressif modules to vibration from ultrasonic equipment, such as ultrasonic welders or ultrasonic cleaners. This vibration may induce resonance in the in-module crystal and lead to its malfunction or even failure. As a consequence, **the module may stop working or its performance may deteriorate.**

10 Related Documentation and Resources

Related Documentation

- [ESP32-C6 Series Datasheet](#) – Specifications of the ESP32-C6 hardware.
- [ESP32-C6 Technical Reference Manual](#) – Detailed information on how to use the ESP32-C6 memory and peripherals.
- [ESP32-C6 Hardware Design Guidelines](#) – Guidelines on how to integrate the ESP32-C6 into your hardware product.
- *Certificates*
<https://espressif.com/en/support/documents/certificates>
- *Documentation Updates and Update Notification Subscription*
<https://espressif.com/en/support/download/documents>

Developer Zone

- *ESP-IDF* and other development frameworks on GitHub.
<https://github.com/espressif>
- *ESP32 BBS Forum* – Engineer-to-Engineer (E2E) Community for Espressif products where you can post questions, share knowledge, explore ideas, and help solve problems with fellow engineers.
<https://esp32.com/>
- *The ESP Journal* – Best Practices, Articles, and Notes from Espressif folks.
<https://blog.espressif.com/>
- See the tabs *SDKs and Demos, Apps, Tools, AT Firmware*.
<https://espressif.com/en/support/download/sdk-demos>

Products

- *ESP32-C6 Series SoCs* – Browse through all ESP32-C6 SoCs.
<https://espressif.com/en/products/socs?id=ESP32-C6>
- *ESP32-C6 Series Modules* – Browse through all ESP32-C6-based modules.
<https://espressif.com/en/products/modules?id=ESP32-C6>
- *ESP32-C6 Series DevKits* – Browse through all ESP32-C6-based devkits.
<https://espressif.com/en/products/devkits?id=ESP32-C6>
- *ESP Product Selector* – Find an Espressif hardware product suitable for your needs by comparing or applying filters.
<https://products.espressif.com/#/product-selector?language=en>

Contact Us

- See the tabs *Sales Questions, Technical Enquiries, Circuit Schematic & PCB Design Review, Get Samples (Online stores), Become Our Supplier, Comments & Suggestions*.
<https://espressif.com/en/contact-us/sales-questions>

Revision History

Date	Version	Release notes
2023-04-17	v0.6	Added information about ESP32-C6-MINI-1U module
2023-02-16	v0.5	Preliminary release



www.espressif.com

Disclaimer and Copyright Notice

Information in this document, including URL references, is subject to change without notice.

ALL THIRD PARTY'S INFORMATION IN THIS DOCUMENT IS PROVIDED AS IS WITH NO WARRANTIES TO ITS AUTHENTICITY AND ACCURACY.

NO WARRANTY IS PROVIDED TO THIS DOCUMENT FOR ITS MERCHANTABILITY, NON-INFRINGEMENT, FITNESS FOR ANY PARTICULAR PURPOSE, NOR DOES ANY WARRANTY OTHERWISE ARISING OUT OF ANY PROPOSAL, SPECIFICATION OR SAMPLE.

All liability, including liability for infringement of any proprietary rights, relating to use of information in this document is disclaimed. No licenses express or implied, by estoppel or otherwise, to any intellectual property rights are granted herein.

The Wi-Fi Alliance Member logo is a trademark of the Wi-Fi Alliance. The Bluetooth logo is a registered trademark of Bluetooth SIG.

All trade names, trademarks and registered trademarks mentioned in this document are property of their respective owners, and are hereby acknowledged.

Copyright © 2023 Espressif Systems (Shanghai) Co., Ltd. All rights reserved.