

IEC**IECEE**

®

TM

Ref. Certif. No.

JPTUV-118606

IEC SYSTEM FOR MUTUAL RECOGNITION OF TEST CERTIFICATES FOR ELECTRICAL EQUIPMENT
(IECEE) CB SCHEME**CB TEST CERTIFICATE**

Product

Li-ion Polymer Battery

Name and address of the applicant

General Electronics Technology Co., Ltd.
Hongfu Industrial Zone, Huarong Road, Dalang Street, Longhua District,
Shenzhen City, Guangdong, P.R. China

Name and address of the manufacturer

General Electronics Technology Co., Ltd.
Hongfu Industrial Zone, Huarong Road, Dalang Street, Longhua District,
Shenzhen City, Guangdong, P.R. China

Name and address of the factory

General Electronics Technology Co., Ltd.
Hongfu Industrial Zone, Huarong Road, Dalang Street, Longhua District,
Shenzhen City, Guangdong, P.R. China

Ratings and principal characteristics

3.7V, 4000mAh, 14.8Wh

Trademark (if any)

N/A
GEB 125054PL

Customer's Testing Facility (CTF) Stage used

Model / Type Ref.

Additional information (if necessary may
also be reported on page 2)IEC 62133-2:2017
See Test Report for National DifferencesA sample of the product was tested and
found to be in conformity withAs shown in the Test Report Ref. No. which
forms part of this Certificate

CN20PWKV 0001

This CB Test Certificate is issued by the National Certification Body

**TÜVRheinland**®TÜV Rheinland Japan Ltd.
Global Technology Assessment Center
4-25-2 Kita-Yamata, Tsuzuki-ku
Yokohama 224-0021, Japan
Phone + 81 45 914-3888
Fax + 81 45 914-3354
Mail: info@jpn.tuv.com
Web : www.tuv.com

Date: 2021-01-15

Signature:

Jason Tang



Test Report issued under the responsibility of:



**TEST REPORT
IEC 62133-2
Secondary cells and batteries containing alkaline or other non-acid electrolytes – Safety requirements for portable sealed secondary cells, and for batteries made from them, for use in portable applications –
Part 2: Lithium systems**

Report Number: CN20PWKV 0001
Date of issue: 2021-01-14
Total number of pages: 24 pages

Name of Testing Laboratory preparing the Report: Shenzhen LCS Compliance Testing Laboratory Ltd.

Applicant's name: Shenzhen Hongshengze Energy Technology Co., Ltd.
Address: Floor 2, Shunfu Science Park, Fudigang No.2 Industrial Zone, Pingdi Street, Longgang District, Shenzhen City, Guangdong, P.R. China

Test specification:
Standard: IEC 62133-2: 2017
Test procedure: CB Scheme
Non-standard test method: N/A

Test Report Form No.: IEC 62133_2A
Test Report Form(s) Originator: DEKRA
Master TRF: Dated 2017-08-10

Copyright © 2017 IEC System of Conformity Assessment Schemes for Electrotechnical Equipment and Components (IECEE System). All rights reserved.
This publication may be reproduced in whole or in part for non-commercial purposes as long as the IECEE is acknowledged as copyright owner and source of the material. IECEE takes no responsibility for and will not assume liability for damages resulting from the reader's interpretation of the reproduced material due to its placement and context.
If this Test Report Form is used by non-IECEE members, the IECEE/IEC logo and the reference to the CB Scheme procedure shall be removed.
This report is not valid as a CB Test Report unless signed by an approved CB Testing Laboratory and appended to a CB Test Certificate issued by an NCB in accordance with IECEE 02.

General disclaimer:
The test results presented in this report relate only to the object tested.
This report shall not be reproduced, except in full, without the written approval of the Issuing CB Testing Laboratory. The authenticity of this Test Report and its contents can be verified by contacting the NCB, responsible for this Test Report.

Test item description	Li-ion Polymer Battery	
Trade Mark	N/A	
Manufacturer.....	General Electronics Technology Co., Ltd. Hongfu Industrial Zone, Huarong Road., Dalang Street, Longhua District, Shenzhen City, Guangdong, P.R. China,	
Model/Type reference.....	GEB 125054PL	
Ratings	3.7V, 4000mAh, 14.8Wh	
Responsible Testing Laboratory (as applicable), testing procedure and testing location(s):		
<input checked="" type="checkbox"/>	CB Testing Laboratory:	Shenzhen LCS Compliance Testing Laboratory Ltd.
Testing location/ address	1, 2F, Building A & 3F, Building C, Juji Industrial Park, Yabianxueziwei, Shajing Street, Bao'an District, Shenzhen, Guangdong, China	
Tested by (name, function, signature)	Dean Du(Engineer)	<i>Dean Du</i>
Approved by (name, function, signature) ...:	Hart Qiu(Reviewer)	<i>Hart Qiu</i>
<input type="checkbox"/>	Testing procedure: CTF Stage 1:	
Testing location/ address		
Tested by (name, function, signature)		
Approved by (name, function, signature) ...:		
<input type="checkbox"/>	Testing procedure: CTF Stage 2:	
Testing location/ address		
Tested by (name + signature)		
Witnessed by (name, function, signature) ..:		
Approved by (name, function, signature) ...:		
<input type="checkbox"/>	Testing procedure: CTF Stage 3:	
<input type="checkbox"/>	Testing procedure: CTF Stage 4:	
Testing location/ address		
Tested by (name, function, signature)		
Witnessed by (name, function, signature) ..:		
Approved by (name, function, signature) ...:		
Supervised by (name, function, signature) :		

List of Attachments (including a total number of pages in each attachment):	
Attachment 1: National Differences (3 pages)	
Attachment 2: Photo Documentation (4 pages)	
Summary of testing:	
<p>Tests performed (name of test and test clause):</p> <p>cl.5.6.2 Design recommendation;</p> <p>cl.7.1 Charging procedure for test purposes (for Cells and Batteries);</p> <p>cl.7.2.1 Continuous charging at constant voltage (Cells);</p> <p>cl.7.2.2 Case stress at high ambient temperature (Batteries);</p> <p>cl.7.3.1 External short-circuit (Cells);</p> <p>cl.7.3.2 External short-circuit (Batteries);</p> <p>cl.7.3.3 Free fall (Cells and Batteries);</p> <p>cl.7.3.4 Thermal abuse (Cells);</p> <p>cl.7.3.5 Crush (Cells);</p> <p>cl.7.3.6 Over-charging of battery;</p> <p>cl.7.3.7 Forced discharge (Cells);</p> <p>cl.7.3.8 Mechanical tests (Batteries);</p> <p>cl.7.3.9 Design evaluation – Forced internal short-circuit (Cells).</p> <p>The electrolyte type of this cell doesn't belong to polymer, and the additional test cl.7.3.9 was carried out to evaluate the cell.</p> <p>Tests are made with the number of cells and batteries specified in IEC 62133-2: 2017 Table 1.</p>	<p>Testing location:</p> <p>Shenzhen LCS Compliance Testing Laboratory Ltd. 1, 2F, Building A & 3F, Building C, Juji Industrial Park, Yabianxueziwei, Shajing Street, Bao'an District, Shenzhen, Guangdong, China</p>
Summary of compliance with National Differences (List of countries addressed):	
KR	
KR=Republic of Korea	
<input checked="" type="checkbox"/> The product fulfils the requirements of <u>EN 62133-2: 2017</u>	

Copy of marking plate:

The artwork below may be only a draft. The use of certification marks on a product must be authorized by the respective NCBs that own these marks.

Li-ion Polymer Battery +(Red) -(Black)

Model: GEB 125054PL

3.7V, 4000mAh, 14.8Wh

1 INP 12/50/55

Date:2020/10

General Electronics Technology Co., Ltd

Warning:

Do not disassemble, puncture, crush, heat, or burn

Test item particulars:	
Classification of installation and use:	To be defined in final product
Supply Connection	DC lead wire
Recommend charging method declared by the manufacturer	Charging the battery with 800mA constant current until 4.2V, then constant voltage charge until current reduces to 80mA at ambient 20°C±5°C.
Discharge current (0,2 It A)	800mA
Specified final voltage:	2.75V
Upper limit charging voltage per cell:	4.2V
Maximum charging current	2000mA
Charging temperature upper limit	45°C
Charging temperature lower limit:	10°C
Polymer cell electrolyte type:	<input type="checkbox"/> gel polymer... <input type="checkbox"/> solid polymer... <input checked="" type="checkbox"/> N/A
Possible test case verdicts:	
- test case does not apply to the test object	N/A
- test object does meet the requirement.....:	P (Pass)
- test object does not meet the requirement.....:	F (Fail)
Testing:	
Date of receipt of test item	2020-12-15
Date (s) of performance of tests	2020-12-15 to 2021-01-06
General remarks:	
<p>The test results presented in this report relate only to the object tested. This report shall not be reproduced, except in full, without the written approval of the Issuing testing laboratory. "(See Enclosure #)" refers to additional information appended to the report. "(See appended table)" refers to a table appended to the report.</p> <p>Throughout this report a <input type="checkbox"/> comma / <input checked="" type="checkbox"/> point is used as the decimal separator.</p>	
Manufacturer's Declaration per sub-clause 4.2.5 of IEC 60335-1:	
The application for obtaining a CB Test Certificate includes more than one factory location and a declaration from the Manufacturer stating that the sample(s) submitted for evaluation is (are) representative of the products from each factory has been provided	<input type="checkbox"/> Yes <input checked="" type="checkbox"/> Not applicable
When differences exist; they shall be identified in the General product information section.	
Name and address of factory (ies)	Same as manufacturer

General product information and other remarks:

The battery is constructed with one lithium-ion cell in 1S1P, and has overcharge, over-discharge, over current and short-circuits proof circuit.

The main features of the battery is shown as below (clause 7.1.1):

Model	Nominal Capacity	Nominal Voltage	Nominal Charge Current	Nominal Discharge Current	Maximum Charge Current	Maximum Discharge Current	Maximum Charge Voltage	Cut-off Voltage
GEB 125054PL (Battery)	4000mAh	3.7V	800mA	800mA	2000mA	2000mA	4.2V	2.75V

The main features of the cell in the battery is shown as below (clause 7.1.1):

Model	Nominal Capacity	Nominal Voltage	Nominal Charge Current	Nominal Discharge Current	Maximum Charge Current	Maximum Discharge Current	Maximum Charge Voltage	Cut-off Voltage
GEB 125054PL (Cell)	4000mAh	3.7V	800mA	800mA	2000mA	2000mA	4.2V	2.75V

The main features of the cell in the battery is shown as below (clause 7.1.2):

Model	Upper Limit Charge Voltage	Taper-off Current	Lower Charge Temperature	Upper Charge Temperature
GEB 125054PL (Cell)	4.2V	200mA	10°C	45°C

Construction:

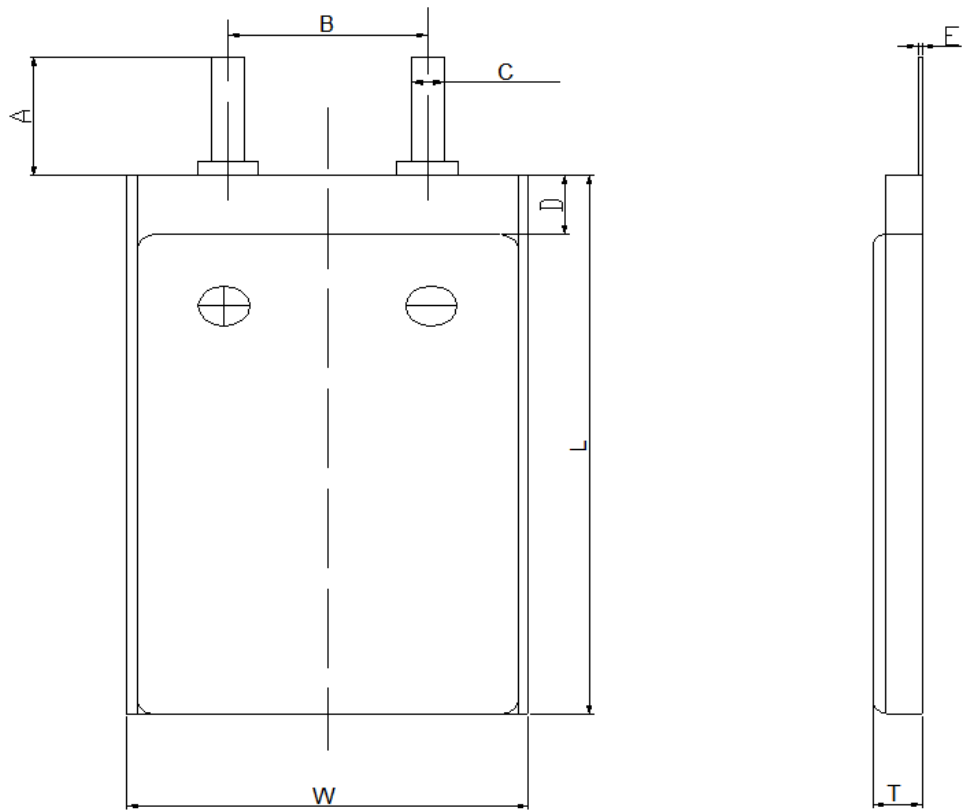

T=12.0mm(max), W=50.0mm(max), L=54.5mm(max)
Cell

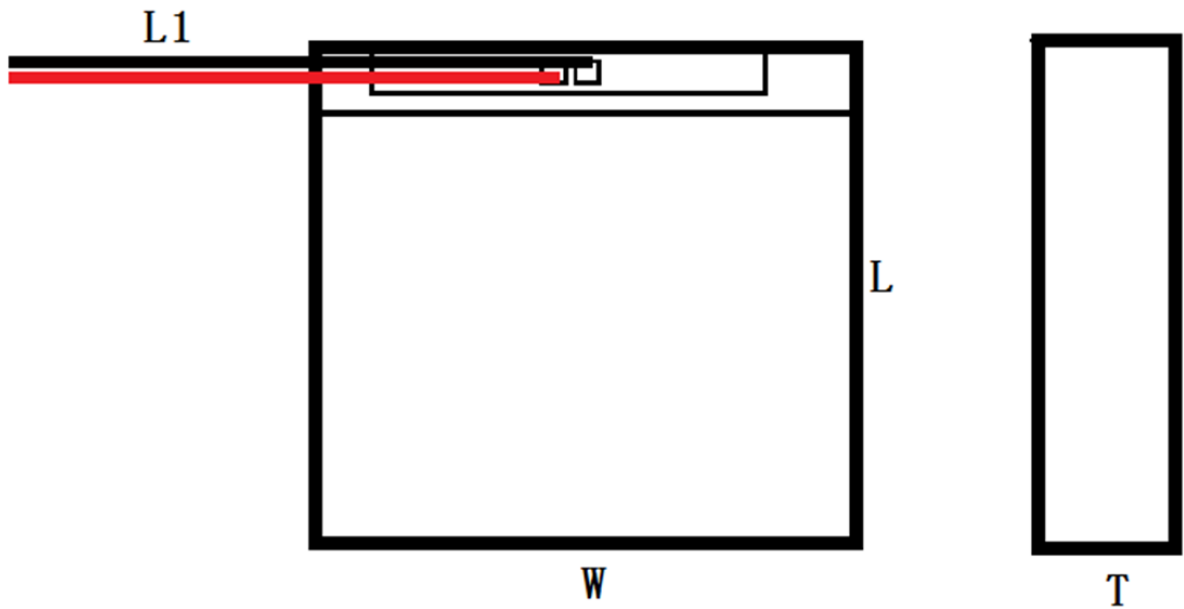

T=12.5mm(max), W=50.5mm(max), L=56.5mm(max)
Battery

Circuit diagram:

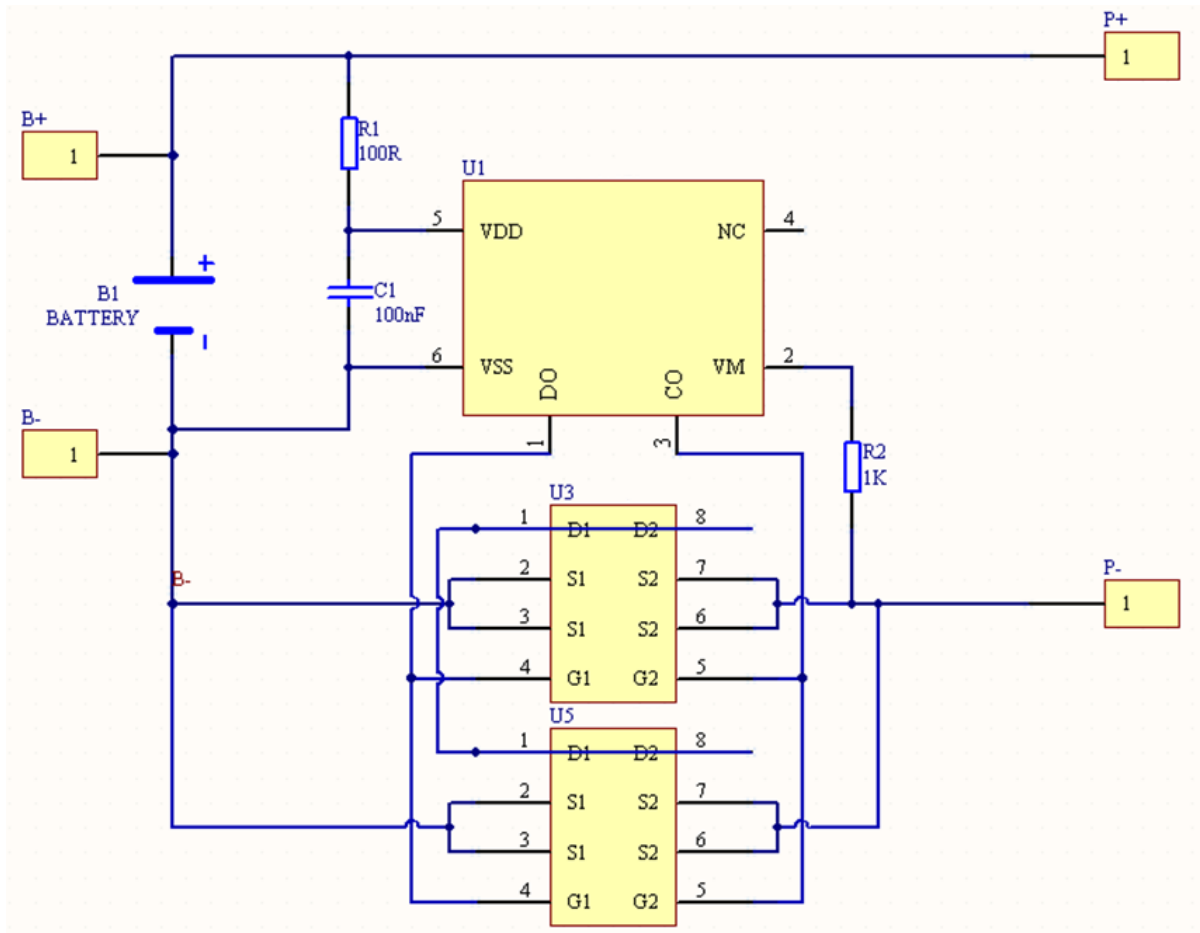

IEC 62133-2: 2017			
Clause	Requirement + Test	Result - Remark	Verdict
4	PARAMETER MEASUREMENT TOLERANCES		P
	Parameter measurement tolerances		P
5	GENERAL SAFETY CONSIDERATIONS		P
5.1	General		P
	Cells and batteries so designed and constructed that they are safe under conditions of both intended use and reasonably foreseeable misuse		P
5.2	Insulation and wiring		P
	The insulation resistance between the positive terminal and externally exposed metal surfaces of the battery (excluding electrical contact surfaces) is not less than 5 MΩ	No metal case exists.	N/A
	Insulation resistance (MΩ) :		—
	Internal wiring and insulation are sufficient to withstand maximum anticipated current, voltage and temperature requirements		P
	Orientation of wiring maintains adequate clearance and creepage distances between conductors		P
	Mechanical integrity of internal connections accommodates reasonably foreseeable misuse		P
5.3	Venting		P
	Battery cases and cells incorporate a pressure relief mechanism or are constructed so that they relieve excessive internal pressure at a value and rate that will preclude rupture, explosion and self-ignition	Venting mechanism exists on narrow side of the cell.	P
	Encapsulation used to support cells within an outer casing does not cause the battery to overheat during normal operation nor inhibit pressure relief		N/A
5.4	Temperature, voltage and current management		P
	Batteries are designed such that abnormal temperature rise conditions are prevented	Overcharge, over discharge, over current and short-circuit proof circuit used in this battery. See tests of clause 7.	P
	Batteries are designed to be within temperature, voltage and current limits specified by the cell manufacturer	See above.	P
	Batteries are provided with specifications and charging instructions for equipment manufacturers so that specified chargers are designed to maintain charging within the temperature, voltage and current limits specified	The charging limits specified in the manufacturer's specification.	P
5.5	Terminal contacts		P
	The size and shape of the terminal contacts ensure that they can carry the maximum anticipated current	DC lead wire complied with the requirements.	P

IEC 62133-2: 2017			
Clause	Requirement + Test	Result - Remark	Verdict
	External terminal contact surfaces are formed from conductive materials with good mechanical strength and corrosion resistance		P
	Terminal contacts are arranged to minimize the risk of short-circuit		P
5.6	Assembly of cells into batteries		P
5.6.1	General		P
	Each battery have an independent control and protection for current, voltage, temperature and any other parameter required for safety and to maintain the cells within their operating region		P
	This protection may be provided external to the battery such as within the charger or the end devices		N/A
	If protection is external to the battery, the manufacturer of the battery provide this safety relevant information to the external device manufacturer for implementation		N/A
	If there is more than one battery housed in a single battery case, each battery have protective circuitry that can maintain the cells within their operating regions	Single cell battery.	N/A
	Manufacturers of cells specify current, voltage and temperature limits so that the battery manufacturer/ designer may ensure proper design and assembly	Current, Voltage and temperature limits specified by cell manufacturer.	P
	Batteries that are designed for the selective discharge of a portion of their series connected cells incorporate circuitry to prevent operation of cells outside the limits specified by the cell manufacturer		N/A
	Protective circuit components added as appropriate and consideration given to the end-device application		P
	The manufacturer of the battery provide a safety analysis of the battery safety circuitry with a test report including a fault analysis of the protection circuit under both charging and discharging conditions confirming the compliance	Safety analysis report provided by manufacturer.	P
5.6.2	Design recommendation		P
	For the battery consisting of a single cell or a single cellblock, it is recommended that the charging voltage of the cell does not exceed the upper limit of the charging voltage specified in Table 2	Max. charging voltage: 4.2V, not exceed 4.2V specified in Clause 7.1.2, Table 2.	P
	For the battery consisting of series-connected plural single cells or series-connected plural cellblocks, it is recommended that the voltages of any one of the single cells or single cellblocks does not exceed the upper limit of the charging voltage, specified in Table 2, by monitoring the voltage of every single cell or the single cellblocks		N/A

IEC 62133-2: 2017			
Clause	Requirement + Test	Result - Remark	Verdict
	For the battery consisting of series-connected plural single cells or series-connected plural cellblocks, it is recommended that charging is stopped when the upper limit of the charging voltage is exceeded for any one of the single cells or single cellblocks by measuring the voltage of every single cell or the single cellblocks		N/A
	For batteries consisting of series-connected cells or cell blocks, nominal charge voltage not be counted as an overcharge protection		N/A
	For batteries consisting of series-connected cells or cell blocks, cells have closely matched capacities, be of the same design, be of the same chemistry and be from the same manufacturer		N/A
	It is recommended that the cells and cell blocks not discharged beyond the cell manufacturer's specified final voltage	Final voltage of cell: 2.75V, not exceed the final voltage specified by the cell manufacturer.	P
	For batteries consisting of series-connected cells or cell blocks, cell balancing circuitry incorporated into the battery management system		N/A
5.6.3	Mechanical protection for cells and components of batteries		P
	Mechanical protection for cells, cell connections and control circuits within the battery provided to prevent damage as a result of intended use and reasonably foreseeable misuse	Mechanical protection for cell connections and control circuits provided.	P
	The mechanical protection can be provided by the battery case or it can be provided by the end product enclosure for those batteries intended for building into an end product	Build-in batteries, mechanical protection for cells should be provided by end product.	N/A
	The battery case and compartments housing cells designed to accommodate cell dimensional tolerances during charging and discharging as recommended by the cell manufacturer	To be evaluated in final systems.	N/A
	For batteries intended for building into a portable end product, testing with the battery installed within the end product considered when conducting mechanical tests		N/A
5.7	Quality plan		P
	The manufacturer prepares and implements a quality plan that defines procedures for the inspection of materials, components, cells and batteries and which covers the whole process of producing each type of cell or battery	Complied. Quality plan provided.	P
5.8	Battery safety components		P
	According annex F	See TABLE: Critical components information.	N/A

IEC 62133-2: 2017			
Clause	Requirement + Test	Result - Remark	Verdict
6	TYPE TEST AND SAMPLE SIZE		P
	Tests are made with the number of cells or batteries specified in Table 1 using cells or batteries that are not more than six months old		P
	Coin cells with resistance $\leq 3 \Omega$ (measured according annex D) are tested according table 1	Not coin cells.	N/A
	Unless otherwise specified, tests are carried out in an ambient temperature of $20 \text{ }^\circ\text{C} \pm 5 \text{ }^\circ\text{C}$		P
	The safety analysis of 5.6.1 identify those components of the protection circuit that are critical for short-circuit, overcharge and overdischarge protection		P
	When conducting the short-circuit test, consideration given to the simulation of any single fault condition that is likely to occur in the protecting circuit that would affect the short-circuit test	See clause 7.3.2.	P
7	SPECIFIC REQUIREMENTS AND TESTS		P
7.1	Charging procedure for test purposes		P
7.1.1	First procedure		P
	This charging procedure applies to subclauses other than those specified in 7.1.2		P
	Unless otherwise stated in this document, the charging procedure for test purposes is carried out in an ambient temperature of $20 \text{ }^\circ\text{C} \pm 5 \text{ }^\circ\text{C}$, using the method declared by the manufacturer		P
	Prior to charging, the battery have been discharged at $20 \text{ }^\circ\text{C} \pm 5 \text{ }^\circ\text{C}$ at a constant current of 0,2 It A down to a specified final voltage	See page 5.	P
7.1.2	Second procedure		P
	This charging procedure applies only to 7.3.1, 7.3.4, 7.3.5, and 7.3.9		P
	After stabilization for 1 h and 4 h, respectively, at ambient temperature of highest test temperature and lowest test temperature, as specified in Table 2, cells are charged by using the upper limit charging voltage and maximum charging current, until the charging current is reduced to 0,05 It A, using a constant voltage charging method	Charge temperature 10~45°C declared. 45°C used for upper limit tests, 10°C used for lower limit tests.	P
7.2	Intended use		P
7.2.1	Continuous charging at constant voltage (cells)	Tested complied.	P
	Fully charged cells are subjected for 7 days to a charge using the charging method for current and standard voltage specified by the cell manufacturer	Charging for 7 days with 800mA.	P
	Results: No fire. No explosion. No leakage.....:	(See appended table 7.2.1)	P

IEC 62133-2: 2017			
Clause	Requirement + Test	Result - Remark	Verdict
7.2.2	Case stress at high ambient temperature (battery)	Tested as client requested.	P
	Oven temperature (°C).....: 70°C		—
	Results: No physical distortion of the battery case resulting in exposure of internal protective components and cells.	No physical distortion of the battery case.	P
7.3	Reasonably foreseeable misuse		P
7.3.1	External short-circuit (cell)	Tested complied.	P
	The cells were tested until one of the following occurred:		P
	- 24 hours elapsed; or		N/A
	- The case temperature declined by 20 % of the maximum temperature rise		P
	Results: No fire. No explosion.....: (See appended table 7.3.1)		P
7.3.2	External short-circuit (battery)	Tested complied.	P
	The batteries were tested until one of the following occurred:		P
	- 24 hours elapsed; or		P
	- The case temperature declined by 20 % of the maximum temperature rise		P
	In case of rapid decline in short circuit current, the battery pack remained on test for an additional one hour after the current reached a low end steady state condition		P
	A single fault in the discharge protection circuit conducted on one to four (depending upon the protection circuit) of the five samples before conducting the short-circuit test	Single fault conducted on four samples.	P
	A single fault applies to protective component parts such as MOSFET, fuse, thermostat or positive temperature coefficient (PTC) thermistor	Single fault applies on MOSFET(U3)(pin2-pin7)	P
	Results: No fire. No explosion.....: (See appended table 7.3.2)		P
7.3.3	Free fall	Tested complied.	P
	Results: No fire. No explosion	No fire. No explosion.	P
7.3.4	Thermal abuse (cells)	Tested complied.	P
	Oven temperature (°C).....: 130°C		—
	Results: No fire. No explosion	No fire. No explosion.	P
7.3.5	Crush (cells)	Tested complied.	P
	The crushing force was released upon:		P
	- The maximum force of 13 kN ± 0,78 kN has been applied; or		P
	- An abrupt voltage drop of one-third of the original voltage has been obtained		N/A

IEC 62133-2: 2017			
Clause	Requirement + Test	Result - Remark	Verdict
	Results: No fire. No explosion..... :	(See appended table 7.3.5)	P
7.3.6	Over-charging of battery	Tested complied.	P
	The supply voltage which is:		--
	- 1,4 times the upper limit charging voltage presented in Table A.1 (but not to exceed 6,0 V) for single cell/cell block batteries or	5.88V applied.	P
	- 1,2 times the upper limit charging voltage resented in Table A.1 per cell for series connected multi-cell batteries, and		N/A
	- Sufficient to maintain a current of 2,0 It A throughout the duration of the test or until the supply voltage is reached		P
	Test was continued until the temperature of the outer casing:		P
	- Reached steady state conditions (less than 10 °C change in 30-minute period); or		N/A
	- Returned to ambient		P
	Results: No fire. No explosion..... :	(See appended table 7.3.6)	P
7.3.7	Forced discharge (cells)	Tested complied.	P
	If the discharge voltage reaches the negative value of upper limit charging voltage within the testing duration, the voltage is maintained at the negative value of the upper limit charging voltage by reducing the current for the remainder of the testing duration		N/A
	If the discharge voltage does not reach the negative value of upper limit charging voltage within the testing duration, the test is terminated at the end of the testing duration		P
	Results: No fire. No explosion..... :	(See appended table 7.3.7)	P
7.3.8	Mechanical tests (batteries)		P
7.3.8.1	Vibration	Tested complied.	P
	Results: No fire, no explosion, no rupture, no leakage or venting. :	(See appended table 7.3.8.1)	P
7.3.8.2	Mechanical shock	Tested complied.	P
	Results: No leakage, no venting, no rupture, no explosion and no fire :	(See appended table 7.3.8.2)	P
7.3.9	Design evaluation – Forced internal short-circuit (cells)	Tested complied.	P
	The cells complied with national requirement for :	France, Japan, Republic of Korea and Switzerland.	—
	The pressing was stopped upon:		P
	- A voltage drop of 50 mV has been detected; or		N/A

IEC 62133-2: 2017			
Clause	Requirement + Test	Result - Remark	Verdict
	- The pressing force of 800 N (cylindrical cells) or 400 N (prismatic cells) has been reached	400N for prismatic cells.	P
	Results: No fire	(See appended table 7.3.9)	P
8	INFORMATION FOR SAFETY		P
8.1	General		P
	Manufacturers of secondary cells ensure that information is provided about current, voltage and temperature limits of their products	Information for safety mentioned in manufacturer's specifications.	P
	Manufacturers of batteries ensure that equipment manufacturers and, in the case of direct sales, end-users are provided with information to minimize and mitigate hazards	Information for safety mentioned in manufacturer's specifications.	P
	Systems analyses performed by device manufacturers to ensure that a particular battery design prevents hazards from occurring during use of a product		N/A
	As appropriate, any information relating to hazard avoidance resulting from a system analysis provided to the end user		N/A
	Do not allow children to replace batteries without adult supervision		N/A
8.2	Small cell and battery safety information	Not small cell and battery.	N/A
	The following warning language is to be provided with the information packaged with the small cells and batteries or equipment using them:		N/A
	- Keep small cells and batteries which are considered swallow able out of the reach of children		N/A
	- Swallowing may lead to burns, perforation of soft tissue, and death. Severe burns can occur within 2 h of ingestion		N/A
	- In case of ingestion of a cell or battery, seek medical assistance promptly		N/A
9	MARKING		P
9.1	Cell marking	The final product is battery.	N/A
	Cells marked as specified in IEC 61960, except coin cells		N/A
	Coin cells whose external surface area is too small to accommodate the markings on the cells show the designation and polarity		N/A
	By agreement between the cell manufacturer and the battery and/or end product manufacturer, component cells used in the manufacture of a battery need not be marked		N/A

IEC 62133-2: 2017			
Clause	Requirement + Test	Result - Remark	Verdict
9.2	Battery marking		P
	Batteries marked as specified in IEC 61960, except for coin batteries	The battery is marked in accordance with IEC 61960, also see page 4.	P
	Coin batteries whose external surface area is too small to accommodate the markings on the batteries show the designation and polarity. Batteries also marked with an appropriate caution statement		P
	Terminals have clear polarity marking on the external surface of the battery	The “+(Red)” and “-(Black)” polarity explicitly marked on surface of the battery.	P
	Batteries with keyed external connectors designed for connection to specific end products need not be marked with polarity markings if the design of the external connector prevents reverse polarity connections		N/A
9.3	Caution for ingestion of small cells and batteries		N/A
	Coin cells and batteries identified as small batteries according to 8.2 include a caution statement regarding the hazards of ingestion in accordance with 8.2	Not coin cells and batteries.	N/A
	When small cells and batteries are intended for direct sale in consumer-replaceable applications, caution for ingestion given on the immediate package		N/A
9.4	Other information		P
	Storage and disposal instructions	Information for storage and disposal instructions mentioned in manufacturer's specifications.	P
	Recommended charging instructions	Information for recommended charging instructions mentioned in manufacturer's specifications.	P
10	PACKAGING AND TRANSPORT		P
	Packaging for coin cells not small enough to fit within the limits of the ingestion gauge of Figure 3	Not coin cells.	N/A
	The materials and packaging design are chosen so as to prevent the development of unintentional electrical conduction, corrosion of the terminals and ingress of environmental contaminants		P

IEC 62133-2: 2017			
Clause	Requirement + Test	Result - Remark	Verdict
ANNEX A	CHARGING AND DISCHARGING RANGE OF SECONDARY LITHIUM ION CELLS FOR SAFE USE		P
A.1	General		P
A.2	Safety of lithium ion secondary battery	Complied.	P
A.3	Consideration on charging voltage	Complied.	P
A.3.1	General		P
A.3.2	Upper limit charging voltage	4.2V	P
A.3.2.1	General		P
A.3.2.2	Explanation of safety viewpoint		N/A
A.3.2.3	Safety requirements, when different upper limit charging voltage is applied	4.2V applied.	N/A
A.4	Consideration of temperature and charging current		P
A.4.1	General		P
A.4.2	Recommended temperature range	See A.4.2.2.	P
A.4.2.1	General		P
A.4.2.2	Safety consideration when a different recommended temperature range is applied	Charging temperature range declared by client is 10~45°C	N/A
A.4.3	High temperature range	Not higher than the temperature specific in this standard.	N/A
A.4.3.1	General		N/A
A.4.3.2	Explanation of safety viewpoint		N/A
A.4.3.3	Safety considerations when specifying charging conditions in the high temperature range		N/A
A.4.3.4	Safety considerations when specifying a new upper limit in the high temperature range		N/A
A.4.4	Low temperature range	Not lower than the temperature specific in this standard.	N/A
A.4.4.1	General		N/A
A.4.4.2	Explanation of safety viewpoint		N/A
A.4.4.3	Safety considerations, when specifying charging conditions in the low temperature range		N/A
A.4.4.4	Safety considerations when specifying a new lower limit in the low temperature range		N/A
A.4.5	Scope of the application of charging current		P
A.4.6	Consideration of discharge		P
A.4.6.1	General		P

IEC 62133-2: 2017			
Clause	Requirement + Test	Result - Remark	Verdict
A.4.6.2	Final discharge voltage and explanation of safety viewpoint	Final voltage of cell: 2.75V, not exceed the final voltage specified by the cell manufacturer.	P
A.4.6.3	Discharge current and temperature range		P
A.4.6.4	Scope of application of the discharging current		P
A.5	Sample preparation		P
A.5.1	General		P
A.5.2	Insertion procedure for nickel particle to generate internal short		P
A.5.3	Disassembly of charged cell		P
A.5.4	Shape of nickel particle		P
A.5.5	Insertion of nickel particle in cylindrical cell		N/A
A.5.5.1	Insertion of nickel particle in winding core		N/A
A.5.5.2	Marking the position of the nickel particle on both ends of the winding core of the separator		N/A
A.5.6	Insertion of nickel particle in prismatic cell		P
A.6	Experimental procedure of the forced internal short-circuit test		P
A.6.1	Material and tools for preparation of nickel particle		P
A.6.2	Example of a nickel particle preparation procedure		P
A.6.3	Positioning (or placement) of a nickel particle		P
A.6.4	Damaged separator precaution		P
A.6.5	Caution for rewinding separator and electrode		P
A.6.6	Insulation film for preventing short-circuit		P
A.6.7	Caution when disassembling a cell		P
A.6.8	Protective equipment for safety		P
A.6.9	Caution in the case of fire during disassembling		P
A.6.10	Caution for the disassembling process and pressing the electrode core		P
A.6.11	Recommended specifications for the pressing device		P

IEC 62133-2: 2017			
Clause	Requirement + Test	Result - Remark	Verdict
ANNEX B	RECOMMENDATIONS TO EQUIPMENT MANUFACTURERS AND BATTERY ASSEMBLERS		N/A
ANNEX C	RECOMMENDATIONS TO THE END-USERS		N/A
ANNEX D	MEASUREMENT OF THE INTERNAL AC RESISTANCE FOR COIN CELLS		N/A
D.1	General	Not coin cells.	N/A
D.2	Method		N/A
	A sample size of three coin cells is required for this measurement..... :		N/A
	Coin cells with an internal resistance of less than or equal to 3 Ω are subjected to the testing according to Clause 6 and Table 1		N/A
	Coin cells with an internal resistance greater than 3 Ω require no further testing		N/A
ANNEX E	PACKAGING AND TRANSPORT		P
ANNEX F	COMPONENT STANDARDS REFERENCES		N/A

TABLE: Critical components information					P
Object/part no.	Manufacturer/trademark	Type/model	Technical data	Standard	Mark(s) of conformity ¹⁾
Cell	General Electronics Technology Co., Ltd.	GEB 125054PL	3.7V, 4000mAh	IEC 62133-2: 2017	Tested with appliance
- Positive Electrode	Soundon New Energy Co.,Ltd	SN2G	Li(Ni _{0.5} Co _{0.2} Mn _{0.3})O ₂ , NMP, PVDF, Conductive Additive, Aluminum Foil	--	--
- Negative Electrode	Chengdu Eminent New Energy Technology Co.,Ltd	E15	Graphite, CMC, SBR, Conductive Additive, Copper Foil	--	--
- Electrolyte	Dongguan Tianfeng Power Material Co.,Ltd	TF-009	LiPF ₆ +EMC+EC+DEC	--	--
- Separator	Dongguan Mochuan New Energy Material Co.,Ltd	12+4	16µm, PE, Shutdown Temperature: 135°C	--	--
Protection IC (U1)	Shenzhen Developer Microelectronics Co., Ltd	DPDW01	Overcharge Protection Voltage: 4.28±0.05V, Over-discharge Protection Voltage: 2.4±0.1V, T _{opr} : -40°C~+85°C	--	Tested with appliance
MOSFET (U3, U5)	Shenzhen Developer Microelectronics Co., Ltd	DP8205	V _{DS} : 20V, V _{GS} : ±12V, I _D : 5A, T _J : -55°C~+150°C	--	Tested with appliance
PCB	SHENZHEN LUTONGDA TECHNOLOGY CO LTD	LTD-D	V-0, 130°C	UL 94 UL 746	UL E486889
PCB (Alternative)	Interchangeable	Interchangeable	Min. V-0, 130°C	UL 94 UL 746	UL Approved
Wire	SHENZHEN DINGYU ELECTRICAL TECHNOLOGY CO LTD	3239	300V, 80°C, 20AWG	UL 758	UL E365423
Supplementary information:					
¹⁾ Provided evidence ensures the agreed level of compliance.					

7.2.1	TABLE: Continuous charging at constant voltage (cells)				P
Sample no.	Recommended charging voltage V _c (Vdc)	Recommended charging current I _{rec} (mA)	OCV before test (Vdc)	Results	
Cell #1	4.2	800	4.19	P	
Cell #2	4.2	800	4.20	P	
Cell #3	4.2	800	4.20	P	
Cell #4	4.2	800	4.20	P	
Cell #5	4.2	800	4.19	P	
Supplementary information:					
- No fire or explosion					
- No leakage					

7.3.1	TABLE: External short-circuit (cells)					P
Sample no.	Ambient T (°C)	OCV before test (Vdc)	Resistance of circuit (mΩ)	Maximum case temperature rise ΔT, (°C)	Results	
Samples charged at charging temperature upper limit (45°C)						
Cell #6	55.2	4.18	84	89.0	P	
Cell #7	55.2	4.18	83	90.3	P	
Cell #8	55.2	4.19	89	103.6	P	
Cell #9	55.2	4.19	76	86.9	P	
Cell #10	55.2	4.19	73	90.5	P	
Samples charged at charging temperature lower limit (10°C)						
Cell #11	56.9	4.13	86	103.7	P	
Cell #12	56.9	4.12	78	87.1	P	
Cell #13	56.9	4.12	79	86.6	P	
Cell #14	56.9	4.12	84	87.0	P	
Cell #15	56.9	4.13	75	94.8	P	
Supplementary information:						
- No fire or explosion						

7.3.2	TABLE: External short-circuit (batteries)					P
Sample no.	Ambient (°C)	OCV before test (Vdc)	Resistance of circuit (mΩ)	Maximum case temperature rise ΔT , (°C)	Component single fault condition	Results
Battery #4	23.7	4.16	85	108.3	MOSFET(U3) (pin2-pin7) Short Circuit	P
Battery #5	23.7	4.16	74	114.8	MOSFET(U3) (pin2-pin7) Short Circuit	P
Battery #6	23.7	4.17	76	103.3	MOSFET(U3) (pin2-pin7) Short Circuit	P
Battery #7	23.7	4.17	72	105.0	MOSFET(U3) (pin2-pin7) Short Circuit	P
Battery #8	23.7	4.17	89	23.8	--	P
Supplementary information:						
- No fire or explosion						

7.3.5	TABLE: Crush (cells)				P
Sample no.	OCV before test (Vdc)	OCV at removal of crushing force (Vdc)	Maximum force applied to the cell during crush (kN)	Results	
Samples charged at charging temperature upper limit (45°C)					
Cell #29	4.18	4.18	13	P	
Cell #30	4.19	4.19	13	P	
Cell #31	4.18	4.17	13	P	
Cell #32	4.18	4.18	13	P	
Cell #33	4.19	4.19	13	P	
Samples charged at charging temperature lower limit (10°C)					
Cell #34	4.13	4.13	13	P	
Cell #35	4.13	4.12	13	P	
Cell #36	4.12	4.12	13	P	
Cell #37	4.12	4.12	13	P	
Cell #38	4.12	4.12	13	P	
Supplementary information:					
- No fire or explosion					

7.3.6		TABLE: Over-charging of battery			P
Constant charging current (A)		8.0			—
Supply voltage (Vdc)		5.88			—
Sample no.	OCV before charging (Vdc)	Total charging time (minute)	Maximum outer case temperature (°C)	Results	
Battery #12	3.04	124	43.0	P	
Battery #13	3.05	124	43.6	P	
Battery #14	3.05	124	43.6	P	
Battery #15	3.04	124	45.3	P	
Battery #16	3.04	124	45.5	P	
Supplementary information:					
- No fire or explosion					

7.3.7		TABLE: Forced discharge (cells)			P
Sample no.	OCV before application of reverse charge (Vdc)	Measured reverse charge I_t (mA)	Lower limit discharge voltage (Vdc)	Results	
Cell #39	3.04	4000	2.75	P	
Cell #40	3.04	4000	2.75	P	
Cell #41	3.05	4000	2.75	P	
Cell #42	3.04	4000	2.75	P	
Cell #43	3.04	4000	2.75	P	
Supplementary information:					
- No fire or explosion					

7.3.8.1		TABLE: Vibration(batteries)				P
Sample no.	OCV before test (Vdc)	OCV after test (Vdc)	Mass before test (g)	Mass after test (g)	Results	
Battery #17	4.16	4.15	65.948	65.945	P	
Battery #18	4.16	4.15	65.427	65.424	P	
Battery #19	4.17	4.17	65.831	65.829	P	
Supplementary information:						
- No fire or explosion						
- No rupture						
- No leakage						
- No venting						

7.3.8.2	TABLE: Mechanical shock(batteries)					P
Sample no.	OCV before test (Vdc)	OCV after test (Vdc)	Mass before test (g)	Mass after test (g)	Results	
Battery #20	4.17	4.16	65.257	65.254	P	
Battery #21	4.16	4.16	65.693	65.690	P	
Battery #22	4.17	4.16	65.589	65.587	P	
Supplementary information:						
- No fire or explosion - No rupture - No leakage - No venting						

7.3.9	TABLE: Forced internal short circuit (cells)					P
Sample no.	Chamber ambient T (°C)	OCV before test (Vdc)	Particle location ¹⁾	Maximum applied pressure (N)	Results	
Samples charged at charging temperature upper limit (45°C)						
Cell #44	45	4.19	1	400	P	
Cell #45	45	4.18	1	400	P	
Cell #46	45	4.18	1	400	P	
Cell #47	45	4.18	1*	400	P	
Cell #48	45	4.19	1*	400	P	
Samples charged at charging temperature lower limit (10°C)						
Cell #49	10	4.12	1	400	P	
Cell #50	10	4.12	1	400	P	
Cell #51	10	4.13	1	400	P	
Cell #52	10	4.13	1*	400	P	
Cell #53	10	4.12	1*	400	P	
Supplementary information:						
¹⁾ Identify one of the following: 1: Nickel particle inserted between positive and negative (active material) coated area. 2: Nickel particle inserted between positive aluminium foil and negative active material coated area. - No fire Remark: *No position 2						

D.2	TABLE: Internal AC resistance for coin cells				N/A
Sample no.	Ambient T (°C)	Store time (h)	Resistance Rac (Ω)	Results ¹⁾	
Supplementary information:					
¹⁾ Coin cells with internal resistance less than or equal to 3 Ω, see test result on corresponding tables					

-- End of Report --

IEC62133_2A ATTACHMENT			
Clause	Requirement + Test	Result - Remark	Verdict
ATTACHMENT TO TEST REPORT IEC 62133-2 (Republic of Korea) NATIONAL DIFFERENCES (Secondary cells and batteries containing alkaline or other non-acid electrolytes - Safety requirements for portable sealed secondary lithium cells, and for batteries made from them, for use in portable applications - Part 2: Lithium systems)			
Differences according to : National standard KC62133-2(2020-07)			
TRF template used: : IECEE OD-2020-F3, Ed. 1.1			
Attachment Form No. : KR_ND_IEC62133_2A			
Attachment Originator : KTR			
Master Attachment..... : Dated 2020-09-25			
Copyright © 2020 IEC System for Conformity Testing and Certification of Electrical Equipment (IECEE), Geneva, Switzerland. All rights reserved.			
	National Differences		P
7.3.6	Over-charging of battery		P
(Revision)	[Add the bolded text] b) Test The test shall be carried out in an ambient temperature of 20 °C ± 5 °C. Each test battery shall be discharged at a constant current of 0,2 It A, to a final discharge voltage specified by the manufacturer. Sample batteries shall then be charged at a constant current of 2,0 It A, using a supply voltage which is: <ul style="list-style-type: none"> • 1,4 times the upper limit charging voltage presented in Table A.1 (but not to exceed 6,0 V) for single cell/cell block batteries or • 1,2 times the upper limit charging voltage presented in Table A.1 per cell for series connected multi-cell batteries, and • sufficient to maintain a current of 2,0 It A throughout the duration of the test or until the supply voltage is reached. <u>• In case the charging voltage specified by the manufacturer is higher than the overcharge test voltage, the maximum charging voltage specified by manufacturer should be applied with 2.0 ItA, (e.g., quick charging power bank, etc.)</u>	See main report	P

IEC62133_2A ATTACHMENT			
Clause	Requirement + Test	Result - Remark	Verdict
	<p>[Replace to the following statement]</p> <p>c) Acceptance criteria</p> <p>Overcharging exceeding to the limits specified by the manufacturer should not result in fire or explosion.</p>	See table 7.3.6 in main report	P
Annex G	Definition for shape and materials of outer case for cell		P
<i>(Addition)</i>	<p>G.1 General</p> <p>Annex G provides definitions for shape and materials of outer case for cell</p> <p>G.2 Shape of outer case for cell</p> <p>G 2.1 Cylindrical cell</p> <p>Cell with a cylindrical shape in which the overall height is equal to or greater than diameter.</p> <p>G 2.2 Prismatic cell</p> <p>Cell having the shape of a parallelepiped whose faces are rectangular</p> <p>G.3 Materials of outer case for cell</p> <p>G.3.1 Soft case</p> <p>Non-metallic outer case or container for cell</p> <p>G.3.2 Hard case</p> <p>Metallic outer case or container for cell.</p>	<p>(Shape of outer cases)</p> <p><input type="checkbox"/> Cylindrical</p> <p><input checked="" type="checkbox"/> Prismatic</p> <p>(Materials of outer cases)</p> <p><input type="checkbox"/> Hard</p> <p><input checked="" type="checkbox"/> Soft</p>	—
Annex H	Calculation method of the volumetric energy density for cell		P
<i>(Addition)</i>	<p>Annex H provide a calculation method of the volumetric energy density for cell in use of smart phone, tablet, notebook.</p> <p>H.1 General</p> <p>Unless otherwise stated in the Annex E, the dimensions for calculation are based on these for cell before shipment and the volumetric energy density shall be calculated with a maximum values specified by manufacturer. If the specification for cell can't be provided a dimension for calculation, the manufacturer's other documentation shall be provided to demonstrate compliance for its calculation.</p>	452.60Wh/L	—

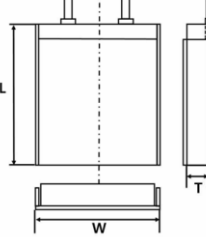
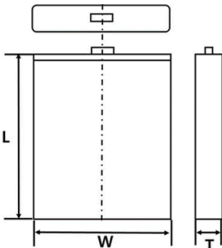
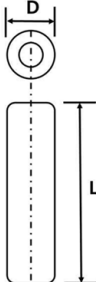
IEC62133_2A ATTACHMENT			
Clause	Requirement + Test	Result - Remark	Verdict
	<p>H.2 Calculation Method</p>  <p>L : Length (max.) of cell (including terrace) W : Width (max.) of cell T : Thickness (max.) when shipping charge (For reference, Please Exclude the dimension of any tape that is attached to cell)</p> $\text{Volumetric energy density (Wh/L)} = \frac{\text{Nominal voltage (V)} \times \text{Rated capacity (Ah)}}{\text{Length (L)} \times \text{Width (W)} \times \text{Thickness (T)}}$ <p>[H.1 – Prismatic cell using soft case]</p>  <p>L : Length (max.) of cell W : Width (max.) of cell T : Thickness when shipping charge (For reference, Please Exclude the dimension of any tape that is attached to cell)</p> $\text{Volumetric energy density (Wh/L)} = \frac{\text{Nominal voltage (V)} \times \text{Rated capacity (Ah)}}{\text{Length (L)} \times \text{Width (W)} \times \text{Thickness (T)}}$ <p>[H.2 – Prismatic cell using hard case]</p>  <p>D : Diameter (max.) of cell L : Length (max.) of cell (According to shape of cell at shipping, The dimension of tube for cell may be included in overall dimension of cell)</p> $\text{Volumetric energy density (Wh/L)} = \frac{\text{Nominal voltage (V)} \times \text{Rated capacity (Ah)}}{3.14159 \times \frac{\text{Diameter (D)}^2}{4} \times \text{Length(L)}}$ <p>[H.3 – Cylindrical cell using hard case]</p>		—

Product: Li-ion Polymer Battery

Type Designation: GEB 125054PL

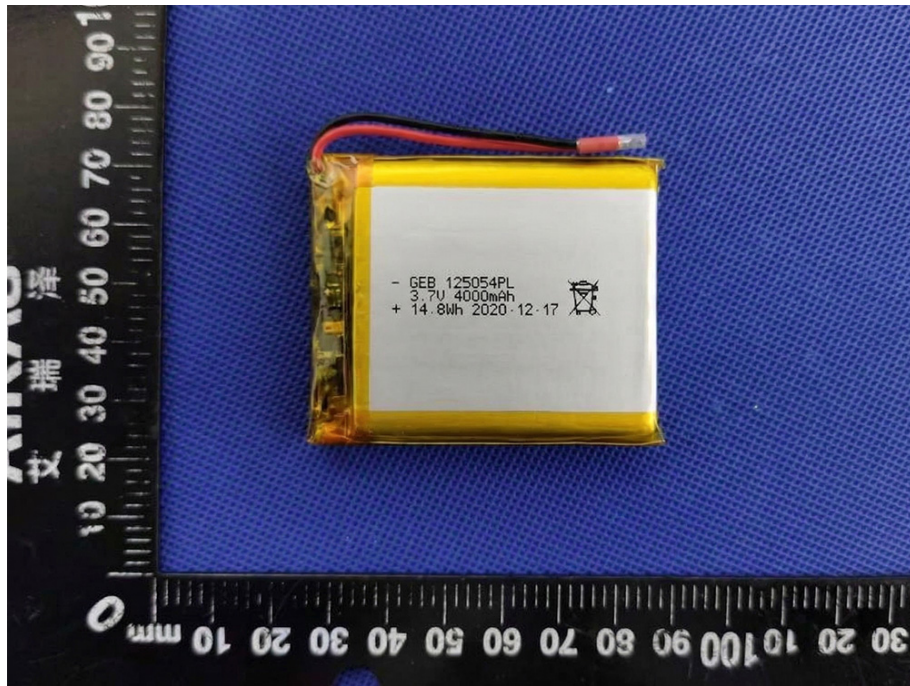

Figure 1 Front view of battery

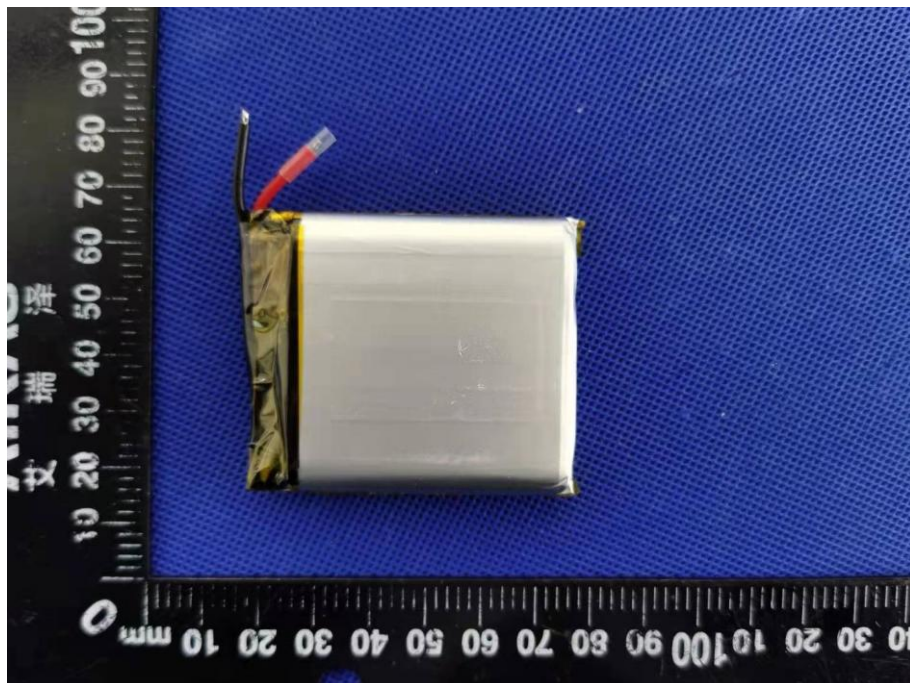

Figure 2 Back view of battery

Product: Li-ion Polymer Battery

Type Designation: GEB 125054PL

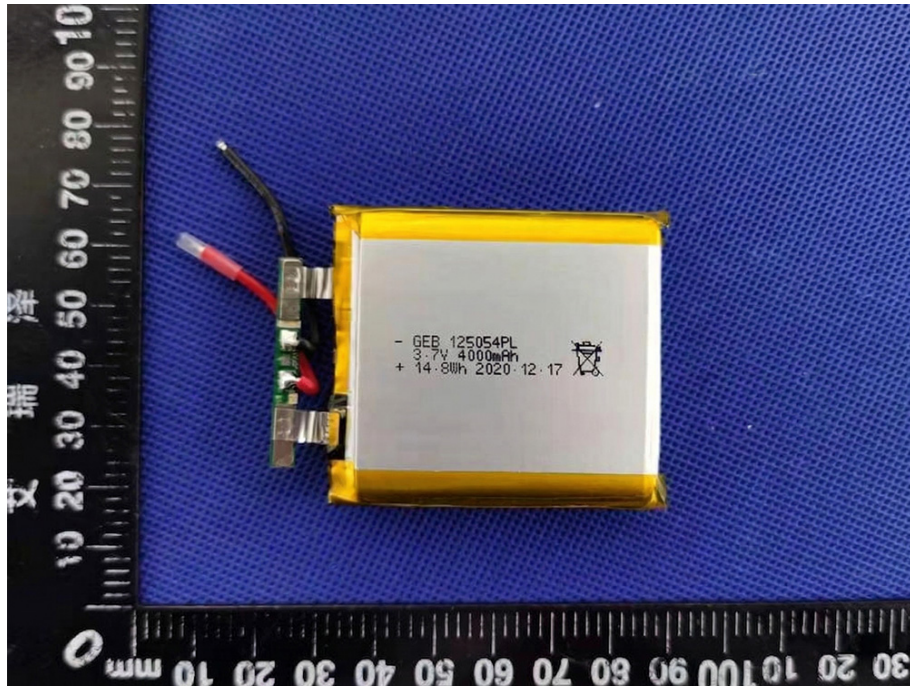

Figure 3 Internal view-1 of battery

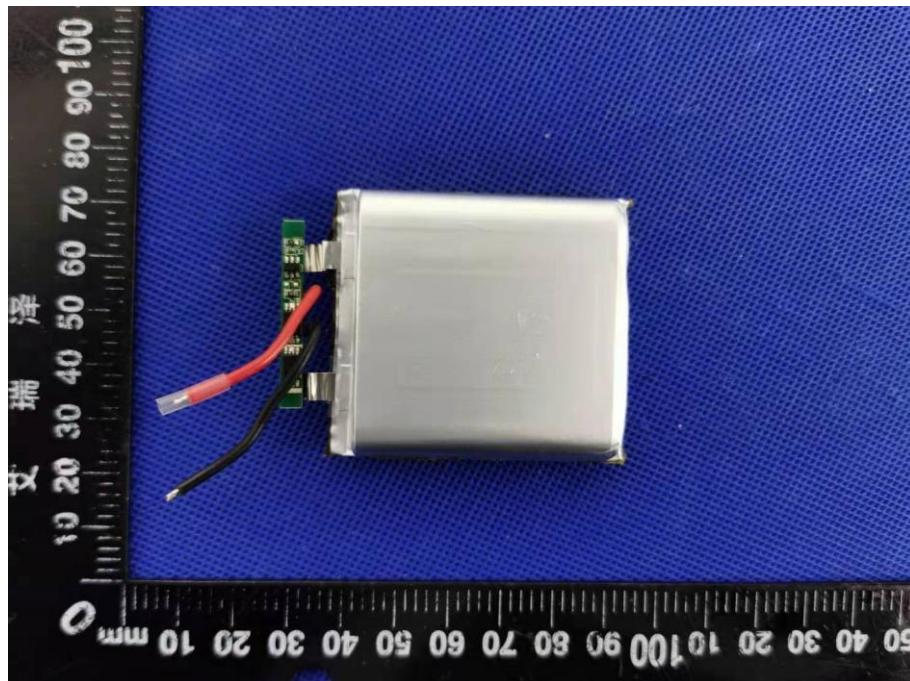

Figure 4 Internal view-2 of battery

Product: Li-ion Polymer Battery

Type Designation: GEB 125054PL

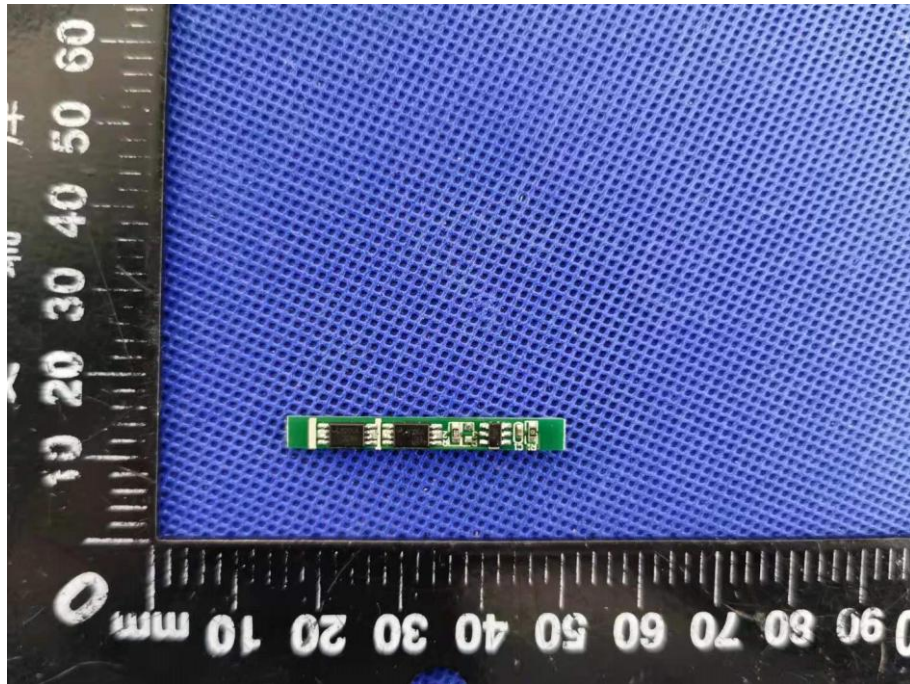

Figure 5 Front view of PCM

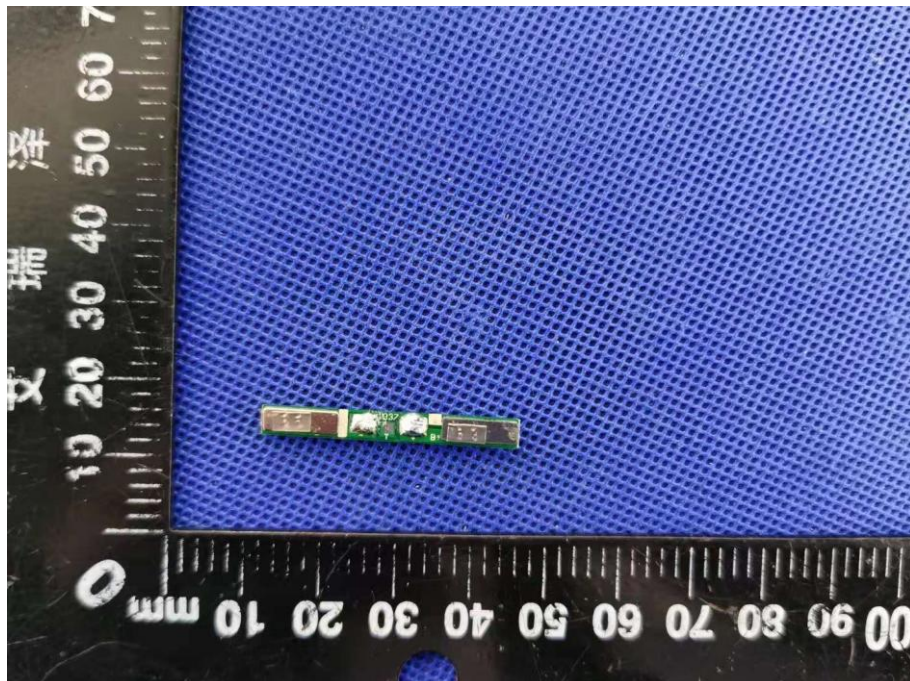

Figure 6 Back view of PCM

Product: Li-ion Polymer Battery

Type Designation: GEB 125054PL

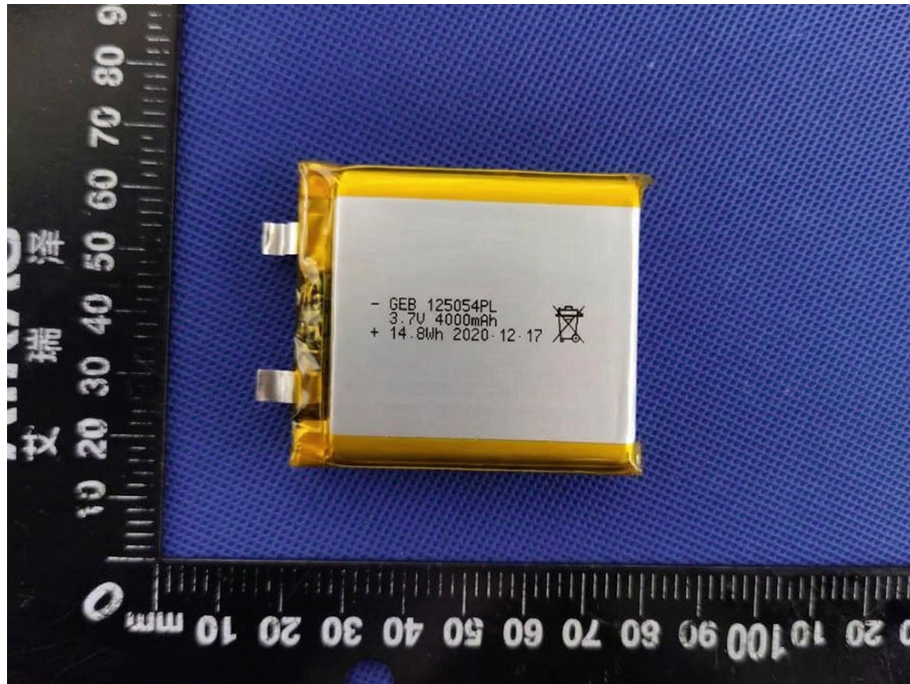

Figure 7 Front view of cell

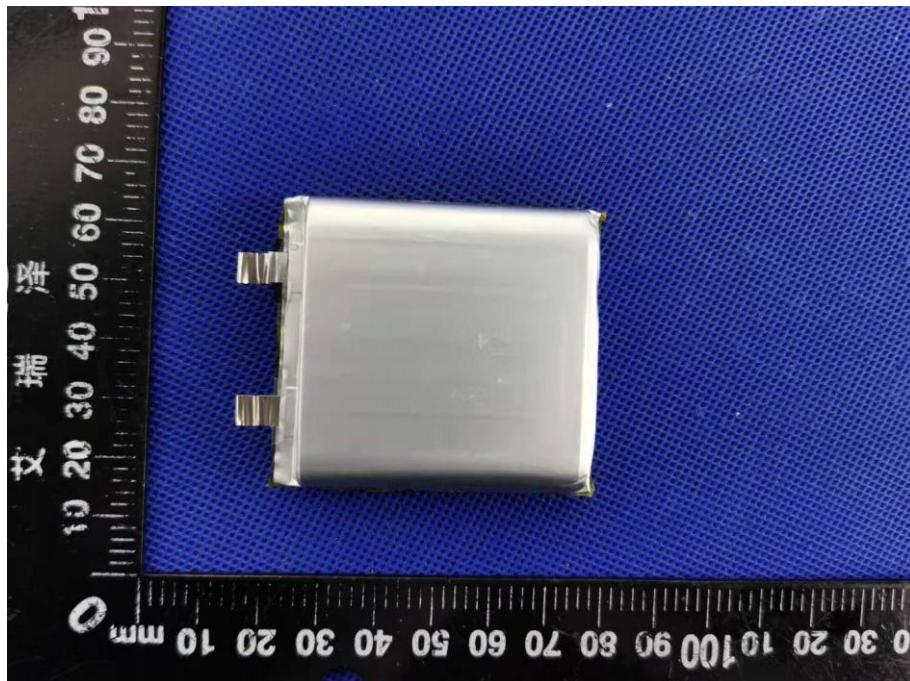

Figure 8 Back view of cell