

Li-ion Cylindrical Battery Specification

圆柱电池规格书

Model: 18650
型号: 18650
Voltage: 3.7V
电压: 3.7V
Nominal Capacity: 3200mAh
标称容量: 3200mAh
Assembled: 1S1P
组合方式: 1S1P
Revision: A
版本: A
Date: 2018-7-4
日期: 2018-7-4
Customer:
客户:

Registered 编制	Checked 审核	Approved 批准

Customer Approved 客户确认		
Dept. 部门	Signature 签名	Date 日期
QA Dept 品质		
R&D Dept 研发		
Approved 批准		

1. Scope 适用范围

The specification shall be applied to Li-ion polymer rechargeable battery pack of 18650 which is manufactured by General Electronics Technology CO., LTD. The product is ROHS compliant.

本规格书适用于深圳市中美通用科技有限公司生产的 18650 可充电锂离子电池，产品满足 ROHS 要求。

2. Battery configuration 电池组成

2.1 Model 电池组总体规格: 3.7V/3200mAh

2.2 Cell 电芯 : 18650

2.3 Size: $d \geq 18.5\text{mm}$, $h \geq 65.5$

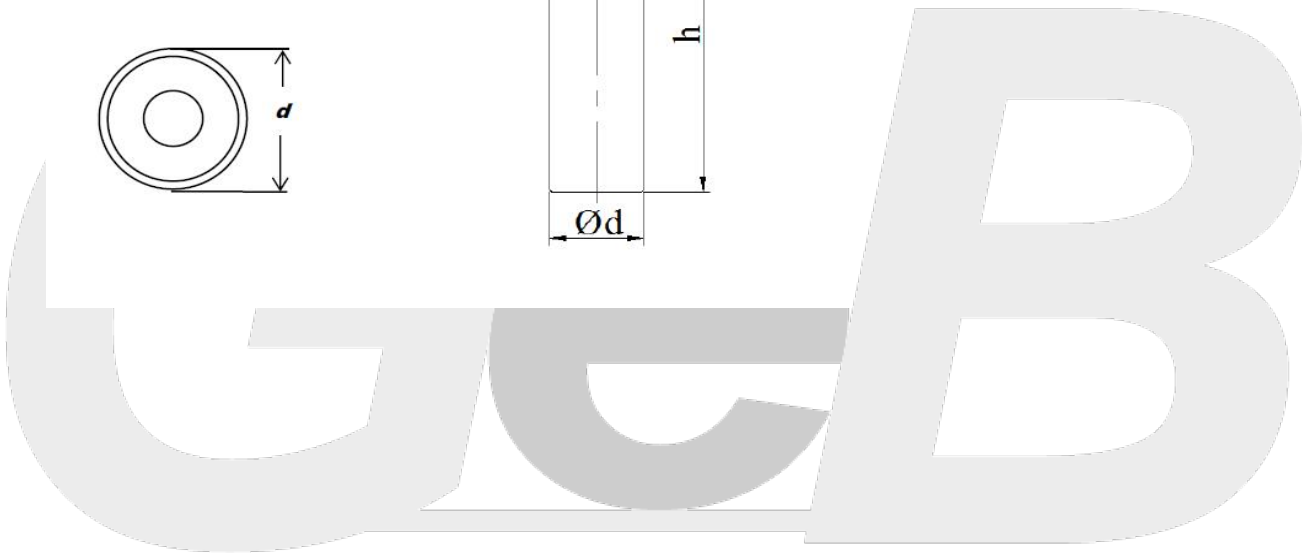
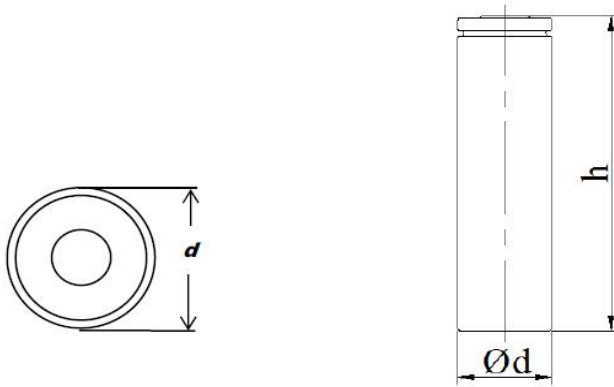

3. Specification 主要技术参数

No.	Items	Criteria	Remarks
3.1	Typical Capacity 典型容量	3200mAh	Discharge:0.2CmA cut-off voltage:2.75V 0.2C 放电至 2.75V 截止
	Minimum Capacity 最小容量	3200mAh	
3.2	Energy 能量	11.84Wh	
3.3	Nominal Voltage 标称电压	3.7V	
3.4	Open Circuit Voltage 出厂电压	≥3.7V	
3.5	Load Voltage 负载电压(33Ω)	≥3.6V	
3.6	Internal Impedance 内阻	≤30mΩ	AC 1KHz after standard charge 标准充电后 AC 1KHz 测试
3.7	Charge voltage 充电电压	4.2V	
3.8	Standard charge current 标准充电电流	640mA	0.2C
3.9	Max. charge current 最大充电电流	1600mA	0.5C
3.10	Standard discharge current 标准放电电流	3200mA	1C
3.11	Max. Continuous discharge current 最大放电电流	4800mA	1.5C
3.12	Peak discharge current 瞬间放电电流	9600mA	3C(last 5s)
3.13	Discharge cut-off voltage 放电截止电压	2.75V	
3.14	Operating Temperature 工作温度	-10~+45℃	Charging 充电
		-10~+45℃	Discharging 放电
3.15	Storage Temperature 贮存温度	23±5℃	Less than 6 months 小于六个月
3.16	Weight 重量	约 50g	

4. General Performance 常规性能

4.1 Common Performance 产品的常规性能

No.	Items/项目	Testing method and determinant standard /测试方法和判定标准
1	Charge Performance 充电性能	The battery can be charged when using the original charger. The standard charge mode :under the temperature of 20±5℃,charge the battery with the current of 0.2C until the voltage reaches up to 4.2V,then charge with constant voltage until the charge current ≤ 0.01C, then stop charging. 使用原装充电器，能够充电。标准充电模式：在20±5℃条件下，电池用0.2C 充电，当电池电压达到4.2V 时转为恒压充电，直到充电电流小于或等于0.01C 时停止充电。
2	Discharge Performance 放电性能	When connecting with load, the battery can supply power. Charge the battery with standard charge mode, then rest for 0.5h, then discharge with 0.2C until the voltage is 2.75V, and the discharge time is required ≥280min 电池外接负载，能够供电。将电池按标准充电模式充好电后，开路搁置0.5h，再以0.2C 放电至2.75V，要求放电时间≥280min
3	Cycle Performance 循环寿命	Under the temperature of 20±5℃,charge the battery with 0.2C, when the voltage reaches up to 4.2V charge with constant voltage until the charge current≤ 20mA, then stop charging, then rest for 0.5h, then discharge with 0.2C to2.75V. Cycle with the above mode, the test shall be terminated when Discharging Capacity < 80% of Initial Capacity in three consecutive cycles. The cycle life is required≥600 times. 在20±5℃条件下电池按0.2C 充电，当电压达到4.2V 时改为恒压充电，直到充电电流小于或等于20mA 时停止充电,静置0.5h 后，0.2C 放电至2.75V 的方式进行循环，当连续三次放电容量<初始容量80%时寿命为终止,要求循环寿命≥600次。
4	Charged Storage Characteristics 荷电保持能力	Charge the battery with 0.2C, then shift to charge with constant voltage until the voltage reaches up to 4.2V, when the charge current ≤0.01C stop charging; rest under the temperature of 20±5℃ for 28d then discharge with 0.2C to2.75V. The discharge time is required ≥4.0h. 电池按0.2C 充电,当端电压达到4.2V 时改为恒压充电,充电电流小于或等于0.01C时,充电停止;将电池开路放置在20±5℃条件下28 天后，以0.2C 放电至2.75V，要求放电时间≥4.0h。
5	Storage Characteristics 存放性能	Charge the battery ,which is new manufactured shorter than 3 months, with 0.2C until the capacity reaches to 40~50%, after resting for 6 months under the temperature of 20±5℃ and the humidity of 45~75%, then charge with 0.2C to 4.2V then shift to charge with constant voltage, after full-charge rest for 0.5h,then discharge with 0.2C to 2.75V. The discharge time required ≥4 h. 将生产日期到实验日期不足3 个月的电池按0.2C 充入40~50%容量后，放置在温度20±5℃、湿度为45~75%的环境中开路存放6个月，电池按0.2C 充电至4.2V 时改为恒压充电，充饱后；静置0.5h，再以0.2C 放电至2.75V，要求放电时间≥3.5h。

6	Temperature Dependence of Capacity 容量温度特性	35°C~45°C	≥90%	Charge:0.2C,CC/CV,4.2V, current ≤ 0.01C cut-off, at 23±3°C Discharge: at setting temperature 0.2C,CC,2.75V cut-off (Interval for temperature change is 2 ho 4.2V 电流≤0.01C 截止 放电: 指定温度下, 0.2C 恒流放电至 2.75V 截止
		25°C~35°C	≥98%	
		-10°C~25°C	≥80%	

4.2 Safety Performance 产品可靠性

No.	Items/项目	Testing method and determinant standard /测试方法和判定标准
1	High Temperature Characteristics 高温性能	Under the temperature of 20±5°C, after charging the battery with 0.2C, then put the battery into the constant temperature and humidity oven with 55±2°C for 2h, then discharge with 0.2C to 2.75V. The discharge time is required ≥240min and the battery should no deformation and smoking. 在20±5°C条件下, 电池按0.2C 充电结束后, 将电池放入55±2°C的恒温恒湿箱中恒温2h 后, 然后以0.2C 电流放电至2.75V,要求放电时间≥240min,且电池外观无变形、不冒烟。
2	Low Temperature Characteristics 低温性能	Under the temperature of 20±5°C, after charging the battery with 0.2C, then put the battery into the constant temperature and humidity oven with -10±2°C for 16~24h, then discharge with 0.2C to 2.75V. The discharge time is required ≥200min and the battery should no deformation and smoking. 在20±5°C条件下, 电池按0.2C 充电结束后, 将电池放入-10±2°C的恒温恒湿箱中恒温16~24h, 然后以0.2C 电流放电至2.75V,要求放电时间≥200min.且电池外观无变形、不冒烟。
3	Drop Test 跌落实验	Under the temperature of 23±5°C, after full-charging the battery with 0.2C, then drop it freely from 1.2 meter height onto the hard 18~20mm board. The battery should be no fire and explosion, a After test discharge the battery with 0.2C, and the discharge time is required ≥240min(The battery should be cycled no more than 3 times, among them if one time is passed then stop.). 在23±5°C条件下, 电池按0.2C 充满电后, 将电池从1.2米高度自由跌落至厚度为18~20mm 的硬木板上, 要求不起火, 不爆炸。试验结束后, 将电池进行0.2C 放电性能测试, 要求放电时间≥240min (最多可进行3 次循环, 其中任何一次合格即可停止)。

4.3 Safe Characteristic 安全性能

No.	Item 项目	Test Methods and Condition 测试方法和条件	Criteria 标准
1	Over charge testing 过充测试	At 23±5°C, charging batteries with constant current 1C to voltage 5V, then with constant voltage 5V till current decline to 0. Stop test till batteries' temperature 10°C lower than max temperature. 在 23±5°C状态下, 电池用 1C 电流充电至 5V, 然后恒压 5V 让电流下降接近为 0A, 监视电池温度变化, 当电池温度下	No fire or explosion 不起火,不爆炸

		降一峰值低约 10℃时, 停止实验.	
2	Over discharge testing 过放测试	At 23 ± 5℃, According to the requirements of standard charge, the battery will be discharge to cut-off voltage, then connect with external load of 30 ohm for 24 hours. 在 23 ± 5℃ 状态下, 按标准放电的要求放电至终止电压后, 外接 30 Ω 负载放电 24 小时.	No explosion, no fire, no leakage. 不爆炸, 不起火, 无泄液
3	Short-circuit testing 短路测试	At 23 ± 5℃, After standard charging, connect batteries' anode and cathode by wire which impedance less than 50m Ω, keep 6h. 在 23 ± 5℃ 状态下, 标准充电后, 将电池的正负极用一根小于 50m Ω 的导线连接, 放置 6 小时.	No fire or explosion, no leakage. 不起火, 不爆炸, 无泄液

※ Above testing of safe characteristic must be with protective equipment.(安全性能测试应在有保护措施下进行)

5. Storage and Shipment Requirement 存储及运输要求

Item 项目		Requirement 需求
Storage temperature 储存温度	Long period less than 6 month 不超过 6 个月的长期存放	23±5℃
Humidity 湿度	65±20%RH	
Voltage 电压	3.65V~3.95V	

6. CAUTIONS IN USE 使用警告

To ensure proper use of the battery please read the manual carefully before using it. Handling
为了使电池安全的使用及处理请在使用前认真的阅读操作说明

- Do not expose to, dispose of the battery in fire.
- 不能把电池曝晒或丢在火中
- Do not put the battery in a charger or equipment with wrong terminals connected.
- 电池充电时不能把正负极性装反
- Avoid shorting the battery
- 避免短路电池
- Avoid excessive physical shock or vibration.
- 避免过分的物理震动和冲击电池
- Do not disassemble or deform the battery.
- 不能拆解或使电池变形
- Do not immerse in water.
- 不能将电池浸入水中
- Do not use the battery mixed with other different make, type, or model batteries.
- 不能将其它不同厂家, 类型, 型号的电池混合使用
- Keep out of the reach of children.
- 禁止小孩接触电池

. charge and discharge 充放电

- Battery must be charged in appropriate charger only.
- 电池必须在合适的条件下充电
- Never use a modified or damaged charger.
- 决不能用故障的充电器给电池充电
- Do not leave battery in charger over 24 hours.
- 电池持续充电不能超过 24H

. storage 贮存

- Store the battery in a cool, dry and well-ventilated area.
- 电池贮藏在通风干燥的环境中

. disposal 处理

- Regulations vary for different countries. Dispose of in accordance with local regulations.
- 不同国家法规的不同，处理时根据当地的法规。

7. Battery operation instruction 电池操作说明

7.1 Charging 充电

Charging current: Cannot surpass the biggest charging current which in this specification book stipulated.

充电电流：不能超过规格书规定的最大的充电电流

Charging voltage: Does not have to surpass the highest amount which in this specification book stipulated to decide the voltage.

充电电压：不能超过规格书规定的最高的限制电压

Charge temperature: The battery must carry on the charge in the ambient temperature scope which this specification book stipulated.

充电温度：电池充电温度必须按照规格书的温度范围执行

Uses the constant electric current and the constant voltage way charge, the prohibition reverse charges. If the battery positive electrode and the cathode meet instead, can damage the battery.

先恒流后恒压方式充电，禁止颠倒的方式充电。如果电池正负极颠倒充电会带来危险。

7.2 Discharging current 放电电流

The discharging current does not have to surpass this specification book stipulation the biggest discharging current, the oversized electric current electric discharge can cause the battery capacity play to reduce and to cause the battery heat.

电池放电电流不能超过规格书规定的最大放电电流，过大的电流放电会造成电池发热和容量衰减。

7.3 discharge temperature 放电温度

The battery discharge must carry on in the ambient temperature scope which this specification book stipulated

电池放电温度必须按照规格书的温度范围执行

7.4 Over-discharges 过放电

After the short time excessively discharges charges immediately cannot affect the use, but the long time excessively discharges can cause the battery the performance, battery function losing. The battery long-term has not used, has the possibility to be able to be at because of its automatic flashover characteristic certain excessively discharges the condition, for prevented excessively discharges the occurrence, the battery should maintain the certain electric quantity.

短时间的过充过放不影响电池的使用，但是长时间的过放电会影响到电池的功能失效，电池永久性不能适用，可能电池过放还有一个原因是自动能量的消失。预防电池过放的出现，电池应保持一定的电量。

7.5 Storing the Batteries 贮存电池。

The battery should store in the product specification book stipulation temperature range. If has surpasses above for six months the long time storage, suggested you should carry on additional charge to the battery.

电池贮存在规格书规定的温度范围内，如果电池贮存超过六个月，建议你开始给电池充电。

8. Period of Warranty 保质期

The period of warranty is a year from the date of shipment. Guarantees to give a replacement in case of cells with defects proven due to manufacturing process instead of the customers abuse and misuse.

电池的保质期从出货之日算起为一年。如果证明电池的缺陷是在制造过程中形成的而不是由于用户滥用及错误使用造成，本公司负责退换电池。

9. Other The Chemical Reaction 其它化学反应

Because batteries utilize a chemical reaction, battery performance will deteriorate over time even if stored for a long period of time without being used. In addition, if the various usage conditions such as charge, discharge, ambient temperature, etc. are not maintained within the specified ranges the life expectancy of the battery may be shortened or the device in which the battery is used may be damaged by electrolyte leakage. If the batteries cannot maintain a charge for long periods of time, even when they are charged correctly, this may indicate it is time to change the battery.

由于电池是利用化学反应的原理，所以随着时间的增加电池的性能会降低，即使是存放很长一段时间而不使用。如果使用条件如充电、放电及周围环境温度等情形不在指定的使用范围内，也会缩短电池的使用寿命，或者产生漏液导致设备损坏。如果电池长周期不能充电，即使充电方法正确，这样需要更换电池了。

10. Note: 备注

Any other items which are not covered in this specification shall be agreed by both parties.

本说明书未包括事项应由双方协议确定。