

PREPARED BY : DATE T.KAMEDA : Mar.14.2014	<h1 style="text-align: center;">SHARP</h1> <p style="text-align: center;">DISPLAY DEVICE BUSINESS SHARP CORPORATION</p> <h2 style="text-align: center;">SPECIFICATION</h2>	SPEC No. LD-D2114302A
CHECKED BY : DATE H.YAMAGUCHI : Mar.14.2014 		FILE No.
ISSUE : Mar.14.2014		
PAGE : 27 pages		
		APPLICABLE GROUP DISPLAY DEVICE BUSINESS DIVISION

Device Specification for

## TFT-LCD module

MODEL No. **LQ133T1JW01**

CUSTOMER'S APPROVAL

DATE \_\_\_\_\_

BY \_\_\_\_\_

PRESENTED

BY  \_\_\_\_\_

H.Okuno  
 DEPARTMENT GENERAL MANAGER  
 DEVELOPMENT DEPARTMENT I  
 DISPLAY DEVICE UNIT II  
 DISPLAY DEVICE BUSINESS DIVISION



## NOTICE

This publication is the proprietary of SHARP and is copyrighted, with all rights reserved. Under the copyright laws, no part of this publication may be reproduced or transmitted in any form or by any means, electronic or mechanical for any purpose, in whole or in part, without the express written permission of SHARP. Express written permission is also required before sending this publication to third parties except your company and SHARP.

The application circuit examples in this publication are provided to explain the representative applications of SHARP's devices and are not intended to guarantee any circuit design or permit any industrial property right or other rights to be executed. SHARP takes no responsibility for any problems related to any industrial property right or a third party resulting from the use of SHARP's devices, except for those resulting directly from device manufacturing processes.

In the absence of confirmation by device specification sheets, SHARP takes no responsibility for any defects that occur in equipment using any of SHARP's devices, shown in catalogs, data books, etc. Contact SHARP in order to obtain the latest device specification sheets before using any SHARP's device.

SHARP reserves the right to make changes in the specifications, characteristics, data, materials, structures and other contents described herein at any time without notice in order to improve design or reliability. Contact SHARP in order to obtain the latest specification sheets before using any SHARP's device. Manufacturing locations are also subject to change without notice.

Observe the following points when using any device in this technical literature. SHARP takes no responsibility for damage caused by usage deviating from the listed specifications and precautions.

The devices in this publication are designed for general electronic equipment use.

The appropriate design measures should be taken to ensure reliability and safety when SHARP's devices are used for equipment such as:

- Transportation control and safety equipment (i.e., aircraft, trains, automobiles, etc.)
- Traffic signals • Gas leakage sensor breakers • Alarm equipment • Various safety devices etc.

SHARP's devices shall not be used for equipment that requires extremely high level of reliability, such as:

- Military and space applications
- Nuclear power control equipment
- Medical equipment for life support

Contact a SHARP representative, in advance, when intending to use SHARP's devices for any "specific" applications other than those recommended by SHARP.

Contact and consult with a SHARP representative in advance, if there are any questions about the contents of this publication.

## - Table of contents -

	page
1. Application .....	3
2. Overview .....	3
3. Mechanical Specifications .....	3
4. Input Terminals .....	4
4-1 symbol .....	4
4-2 eDP interface .....	5
5. Absolute Maximum Ratings .....	7
6. Electrical Characteristics .....	8
6-1 TFT-LCD panel driving .....	8
6-2 Backlight driving .....	11
7. Timing Characteristics of Input Signals .....	12
7-1 Timing characteristics .....	12
7-2 Input Data Signals and Display Position on the screen .....	13
8. Input Signals, Basic Display Colors and Gray Scale of Each Color .....	14
9. EDID Specification .....	15
9-1 EDID data structure .....	15
10. Optical Characteristics .....	19
11. Display Qualities .....	21
12. Handling Precautions .....	22
13. Packing Condition .....	23
14. Storage Conditions .....	23
Fig.1 Packing form .....	24
15. Marking of product name .....	25
16. RoHS Directive .....	25
17. Reliability Test Items .....	26
Fig.2 Outline Dimensions .....	27

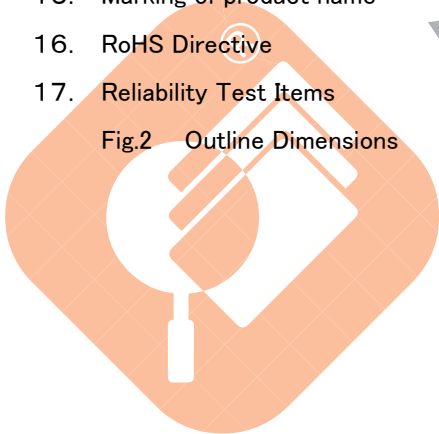

SPLCD.COM  
 Supply & Purchase cloud platform

## 1. Application

This specification applies to a color TFT-LCD module, LQ133T1JW01.

## 2. Overview

This module is a color active matrix LCD module incorporating Oxide TFT (Thin Film Transistor). It is composed of a color TFT-LCD panel, driver ICs, a control circuit and power supply circuit, and a backlight unit. Graphics and texts can be displayed on a 2560 × 3 × 1440 dots panel with 16,777,216 colors by using eDP (Embedded Display Port) to interface and supplying +3.3V DC supply voltage for TFT-LCD panel driving and applying +12V DC supply voltage for LED backlight-driving. In this TFT-LCD panel, color filters for excellent color performance and backlights for high brightness are incorporated to realize brighter and clearer pictures, making this model optimum for use in multi-media applications.

Optimum viewings are in all directions.

Backlight-driving LED controller is built in this module.

eDP Transfer rate Specification : 2.7Gbps / 4 lane

## 3. Mechanical Specifications

Parameter	Specifications	Unit
Display size	33.78 (13.3") Diagonal	cm
Active area	293.76 (H) × 165.24 (V)	mm
Pixel format	2560 (H) × 1440 (V) (1pixel=R+G+B dot)	pixel
Pixel pitch	0.11475 (H) × 0.11475 (V)	mm
Pixel configuration	R,G,B vertical stripe	
Display mode	Normally black	
Display mode	Glare (Hard coat 2H)	
Unit outline dimensions [Note 3-3]	Width	305.35 ± 0.5
	Height	187.90 ± 1.0
	Depth	2.168 ± 0.2 [Note 3-1 3-2]
		2.668 ± 0.25 (LED part) [Note 3-2]
	2.794 ± 0.25 (PWB part)	mm
Mass	195 ± 15	g

[Note 3-1] Except for LED Part and Shading Tape.

[Note 3-2] Measured by the Weighted 200g.

[Note 3-3] Outline dimensions is shown in Fig.2

## 4. Input Terminals

### 4-1. Symbol

CN1 (eDP signals, +3.3V DC power supply, and B/L power supply)

Pin No.	Symbol	I/O	Function	Remark
1	NC	-	Reserved for LCD manufacturer's use	[Note4-1-1]
2	H_GND	P	High Speed Ground	
3	Lane3_N	I	Complement Signal Link Lane 3	
4	Lane3_P	I	True Signal Link Lane 3	
5	H_GND	P	High Speed Ground	
6	Lane2_N	I	Complement Signal Link Lane 2	
7	Lane2_P	I	True Signal Link Lane 2	
8	H_GND	P	High Speed Ground	
9	Lane1_N	I	Complement Signal Link Lane 1	
10	Lane1_P	I	True Signal Link Lane 1	
11	H_GND	P	High Speed Ground	
12	Lane0_N	I	Complement Signal Link Lane 0	
13	Lane0_P	I	True Signal Link Lane 0	
14	H_GND	P	High Speed Ground	
15	AUX_CH_P	I	True Signal Auxiliary Channel	
16	AUX_CH_N	I	Complement Signal Auxiliary Channel	
17	H_GND	P	High Speed Ground	
18	VDD	P	LCD logic and driver power(3.3V)	
19	VDD	P	LCD logic and driver power(3.3V)	
20	VDD	P	LCD logic and driver power(3.3V)	
21	VDD	P	LCD logic and driver power(3.3V)	
22	LCD_GND	P	LCD logic and driver ground	
23	LCD_GND	P	LCD logic and driver ground	
24	LCD_GND	P	LCD logic and driver ground	
25	LCD_GND	P	LCD logic and driver ground	
26	LCD_GND	P	LCD logic and driver ground	
27	HPD	O	HPD signal pin	
28	BL_GND	P	Backlight ground	
29	BL_GND	P	Backlight ground	
30	BL_GND	P	Backlight ground	
31	BL_GND	P	Backlight ground	
32	BL_ENABLE	I	Backlight On/Off	
33	BL_PWM_DIM	I	System PWM	
34	NC	-	Reserved for LCD manufacturer's use	[Note4-1-1]
35	NC	-	Reserved for LCD manufacturer's use	[Note4-1-1]
36	VBL	P	Backlight power	
37	VBL	P	Backlight power	
38	VBL	P	Backlight power	
39	VBL	P	Backlight power	
40	NC	-	Reserved for LCD manufacturer's use	[Note4-1-1]

※I : Input , O : Output , P : Power:

[Note 4-1-1] Don't input any signals or any powers into a NC pin. Keep the NC pin open.

[Note 4-1-2] The shielding case is connected with signal GND.

- Connector used : HD1S040HA1 (JAE)
  - Corresponding connector : HD1P040MA1 (JAE) or 20454-040T (I-PEX)
- (Sharp is not responsible to its product quality, if the user applies a connector not corresponding to the above model.)

#### 4-2. eDP interface

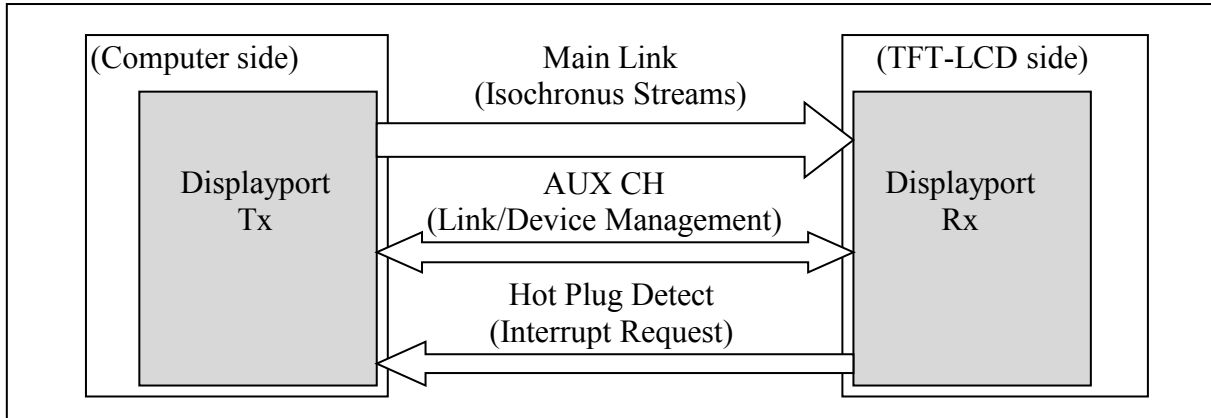

Fig.4-2-1 DP architecture.

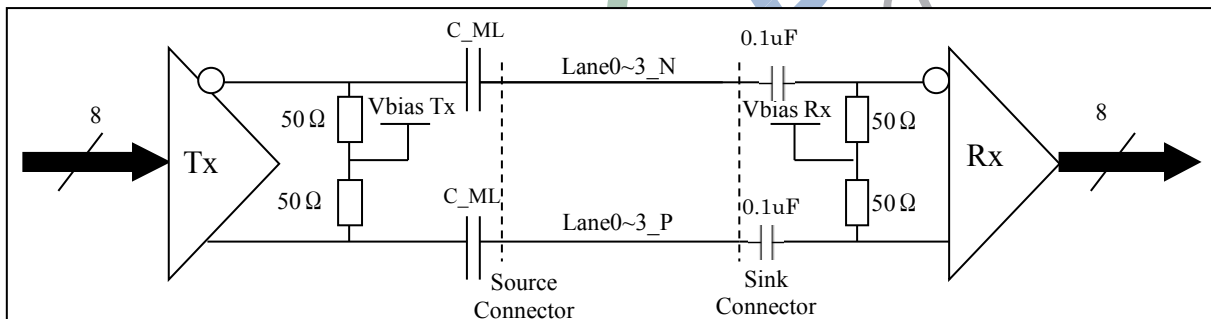

Fig.4-2-2 Main Link differential pair.

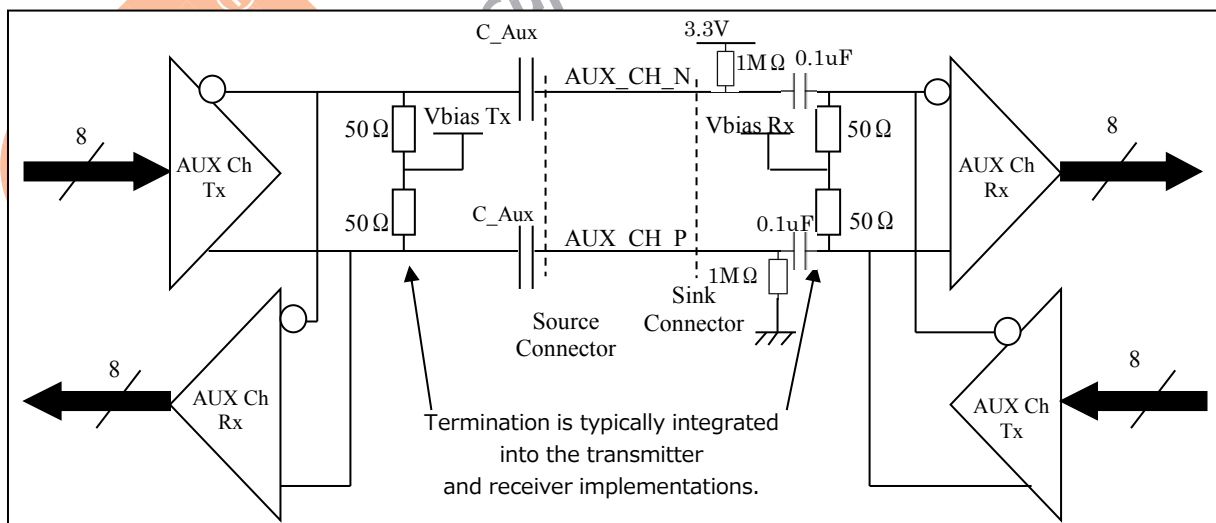

Fig.4-2-3 AUX Link differential pair.

Lane0	Lane1	Lane2	Lane3
R0-7:0	R1-7:0	R2-7:0	R3-7:0
G0-7:0	G1-7:0	G2-7:0	G3-7:0
B0-7:0	B1-7:0	B2-7:0	B3-7:0
R4-7:0	R5-7:0	R6-7:0	R7-7:0
G4-7:0	G5-7:0	G6-7:0	G7-7:0
B4-7:0	B5-7:0	B6-7:0	B7-7:0
R8-7:0	R9-7:0	R10-7:0	R11-7:0
G8-7:0	G9-7:0	G10-7:0	G11-7:0
B8-7:0	B9-7:0	B10-7:0	B11-7:0

Fig.4-2-4 eDP 4 lane 8 bit input data mapping.



SPLCD.com  
Supply & Purchase Cloud Platform



## 5. Absolute Maximum Ratings

### 5-1. Environmental condition

Parameter	non-operation(Storage)	operation	Condition
Ambient temperature	-20~60°C	0~50°C	No condensation.
Humidity	Humidity: 90%RH Max. at $T_a \leq +40^\circ\text{C}$ Maximum wet-bulb temperature at +39°C or less at $T_a > +40^\circ\text{C}$ .		No condensation.

### 5-2. Absolute Maximum Ratings Electrical

Parameter	Symbol	Condition	Min.	Max.	Unit	Remark
+3.3V supply voltage	VDD	$T_a = 25^\circ\text{C}$	-0.3	+4.0	V	
Back Light supply voltage	VBL	$T_a = 25^\circ\text{C}$	-0.3	+3.0	V	
Input voltage(eDP)	V <sub>I</sub>	$T_a = 25^\circ\text{C}$	-0.3	VDD+0.3	V	[Note 5-1]
Input voltage(BL)	V <sub>BL-ENABL</sub> V <sub>PWM</sub>	$T_a = 25^\circ\text{C}$	-0.3	VDD+0.3	V	[Note 5-2]

[Note 5-1] eDP signals

[Note 5-2] Back light control signals (BL\_ENABLE, BL\_PWM\_DIM)



## 6. Electrical Characteristics

### 6-1. TFT-LCD panel driving

Ta = +25°C

DC Electrical Characteristics						
Parameter	Symbol	Min.	Typ.	Max.	Unit	Remark
Supply voltage	VDD	+3.0	+3.3	+3.6	V	
Vsync Frequency	fv	-	60	-	Hz	
Hsync Frequency	fh	-	88.79	-	KHz	
Main Frequency	fdclk	-	241.5	-	MHz	
Current dissipation	IDD	-	420	900	mA	[Note 6-1-2]
Permissive input ripple voltage	V <sub>RP</sub>	-	-	100	mV <sub>p-p</sub>	VDD = +3.3V
eDP AUX Channel Characteristics						
Parameter	Symbol	Min.	Typ.	Max.	Unit	Remark
peak-to-peak voltage	V <sub>AUX-DIFF P-P</sub>	0.32	-	1.32	V	
AUX DC Common Mode Voltage	V <sub>AUX-DC-CM</sub>	0.0	-	2	V	
AUX CH impedance	Z <sub>Aux</sub>	-	100	-	Ω	
eDP Main Link Receiver Characteristics						
Parameter	Symbol	Min.	Typ.	Max.	Unit	Remark
Differential Peak-to-peak Input Voltage at RX package pins	V <sub>RX-DIFF P-P</sub>	120	-	1200	mV	For High bit rate
Differential Peak-to-peak Input Voltage at RX package pins	V <sub>RX-DIFF P-P</sub>	40	-	1200	mV	For Reduced bit rate
RX DC Common Mode Voltage	V <sub>RX-DC-CM</sub>	0	-	2.0	mV	
RX impedance	Z <sub>RX</sub>	-	100	-	Ω	
Lane Intra-pair Skew at RX package pins	L <sub>RX-SKEW-INTRA-PAIR-High-Bit-Rate</sub>	-	-	100.0	ps	
Lane Intra-pair Skew at RX package pins	L <sub>RX-SKEW-INTRA-PAIR-Reduced-Bit-Rate</sub>	-	-	300.0	ps	

[Note 6-1-1] ON-OFF conditions for supply voltage.

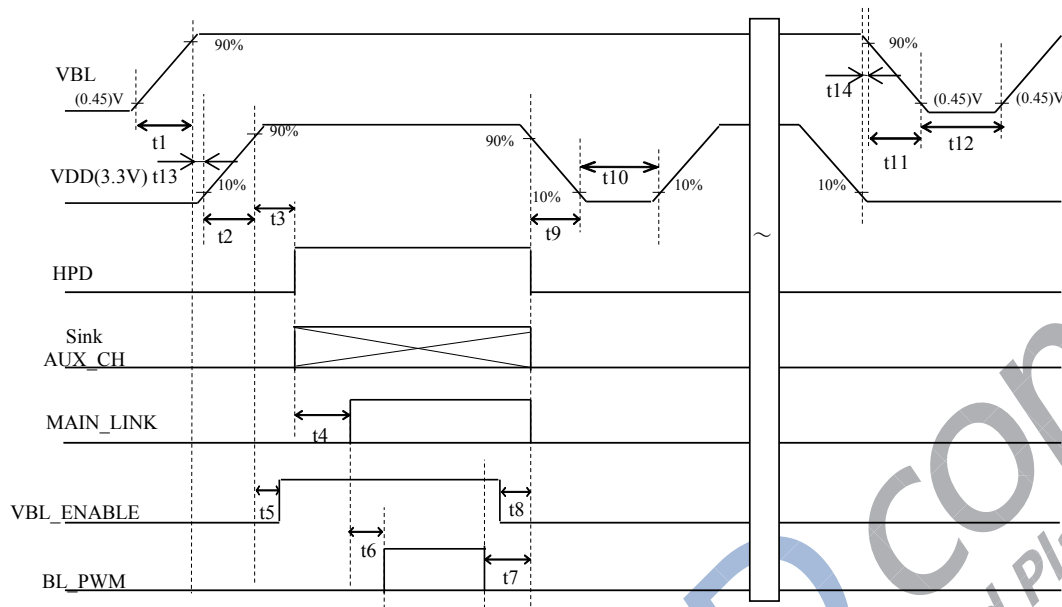

Do not keep the interface signal high-impedance or unusual signal when power is on.

記号 Symbol	Min.	Max.	単位 Unit	備考 Remark
t1	0.1	10	ms	
t2	0.1	10	ms	
t3	120	200	ms	
t4	0	-	ms	
t5	0	-	ms	
t6	17	-	ms	
t7	17	-	ms	
t8	0	-	ms	
t9	10	50	ms	*1
t10	1	-	s	
t11	0.1	-	ms	
t12	1	-	s	
t13	0	-	ms	
t14	0	-	ms	

\*1) As for the power off sequence for VDD (t9), be sure to keep above mentioned timing.

If the VDD power off sequence timing is other than shown above, LCD may cause permanent damage.

\*2) As for the power sequence for backlight, it is recommended to apply above mentioned input timing.

If the backlight is light on and off at a timing other than shown above, displaying image may get disturbed.

VDD-dip conditions

1)  $2.5\text{ V} \leq VDD < 3.0\text{ V}$

$t_d \leq 10\text{ ms}$

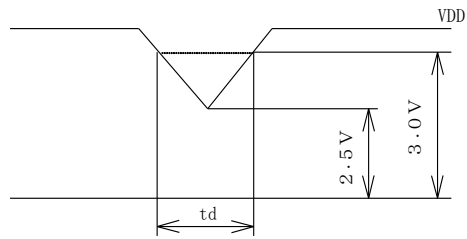

2)  $VDD < 2.5\text{ V}$

VDD-dip conditions should also follow the ON-OFF sequences for input voltage

[Note 6-1-2]

Typical current condition: 16-gray-bar pattern.

$VDD = +3.3\text{ V}$  Typical timing

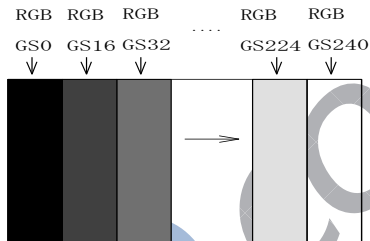

Maximum current condition: Dot checker pattern



SPL.com  
Supply & Purchase Cloud Platform

## 6-2. Backlight driving

The backlight system is an edge-lighting type with white-LED.

Ta=+25°C

Parameter	Symbol	Min.	Typ.	Max.	Unit	Remark
Supply voltage	V <sub>BL</sub>	7.0	12.0	21.0	V	
Current dissipation	I <sub>BL</sub>	-	396	740	mA	V <sub>BL</sub> =12.0V(TYP) V <sub>BL</sub> = 7.0V(MAX) Duty Ratio=100%
PWM signal voltage	V <sub>PWMH</sub>	0.6 × VDD	3.3	3.6	V	
	V <sub>PWML</sub>	0	-	0.4 × VDD	V	
Brightness Control Duty Ratio	Duty	1	-	100	%	[Note6-2-1] [Note6-2-4]
Brightness Control pulse width	T <sub>PWM</sub>	30	-	-	us	[Note6-2-2]
Brightness Control frequency	f <sub>PWM</sub>	150	200	250	Hz	
BL-ENABLE signal voltage	V <sub>BL-ENABL</sub> H	1.8	3.3	3.6	V	[Note6-2-3]
	V <sub>BL-ENABL</sub> L	-	-	0.6	V	
Input signal pin current	I <sub>IN</sub>	-	-	1.0	μ A	V <sub>CNT</sub> , V <sub>PWM</sub> pin
LED lifetime	-	-	10,000	-	h	[Note6-2-5]

[Note6-2-1] PWM Duty Input : 100% = Max luminance 1% = Min luminance

[Note6-2-2] The minimum value of the dimming signal pulse width is assumed regulations of the width of high and the width of low.

[Note6-2-3] VCNT Input : High or OPEN = BL ON, Low =BL OFF

V<sub>BL</sub>-dip conditions

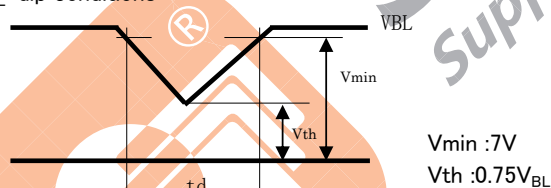

1)  $V_{th} \leq V_{BL} < V_{min}$  :  $t_d \leq 20ms$

2)  $V_{BL} < V_{th}$  : The condition of instantaneous voltage drop is apply to input voltage sequences

[Note6-2-4] When PWM signal is set "L" over 10ms, please reset BL-ENABLE.

If PWM signal is set "L->H" without reset BL-ENABLE, Softstart function of LED driver is invalid and inrush current may occur.

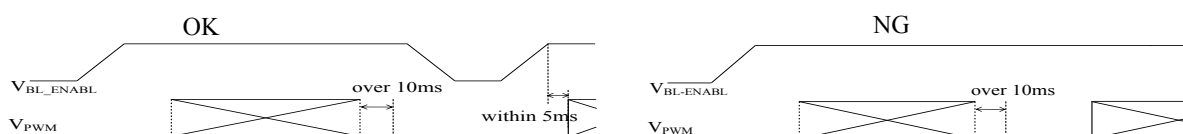

[Note6-2-5] Luminance becomes 50% of an initial value. (Ta=25°C, PWM=100%)

## 7. Timing Characteristics of Input Signals

### 7-1. Timing characteristics

Parameter		Symbol	Min.	Typ.	Max.	Unit	Remark
Data enable Signal	Horizontal period	TH	2720	2720	2720	clock	
	Horizontal period (High)	THd	2560	2560	2560	clock	
	Vertical period	TV	1479	1479	1479	Line	[Note 7-1-1]
	Vertical period (High)	TVd	1440	1440	1440	Line	

[Note 7-1-1] In case of using the long vertical period, the deterioration of display quality, flicker, etc. may occur.

[Note7-1-2] Timing characteristics is based on EDID

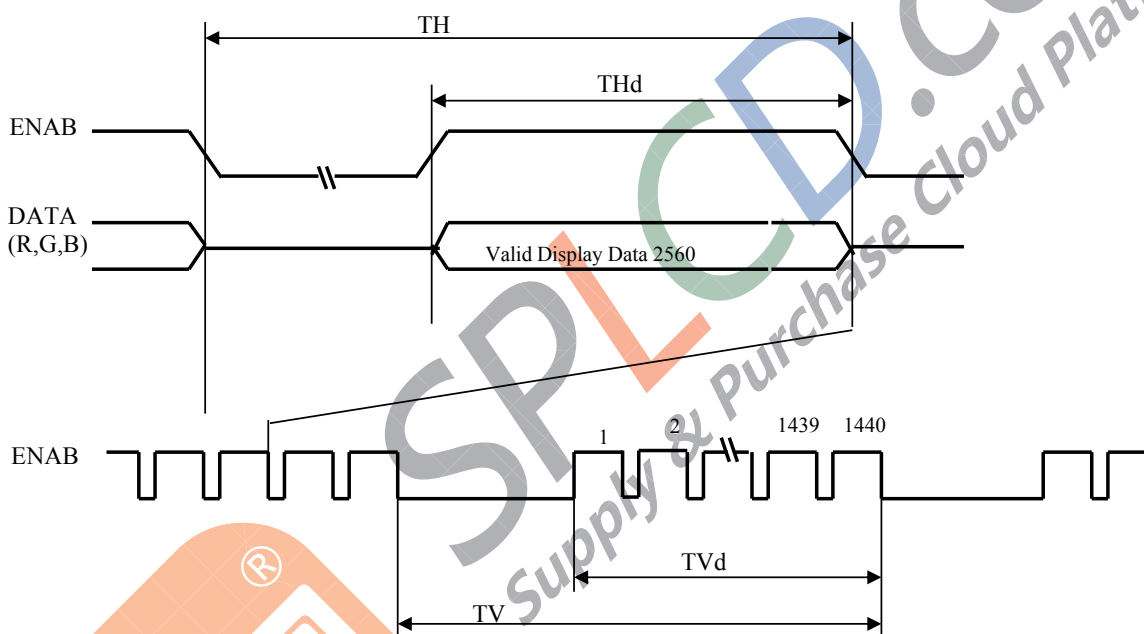

## 7-2. Input Data Signals and Display Position on the screen

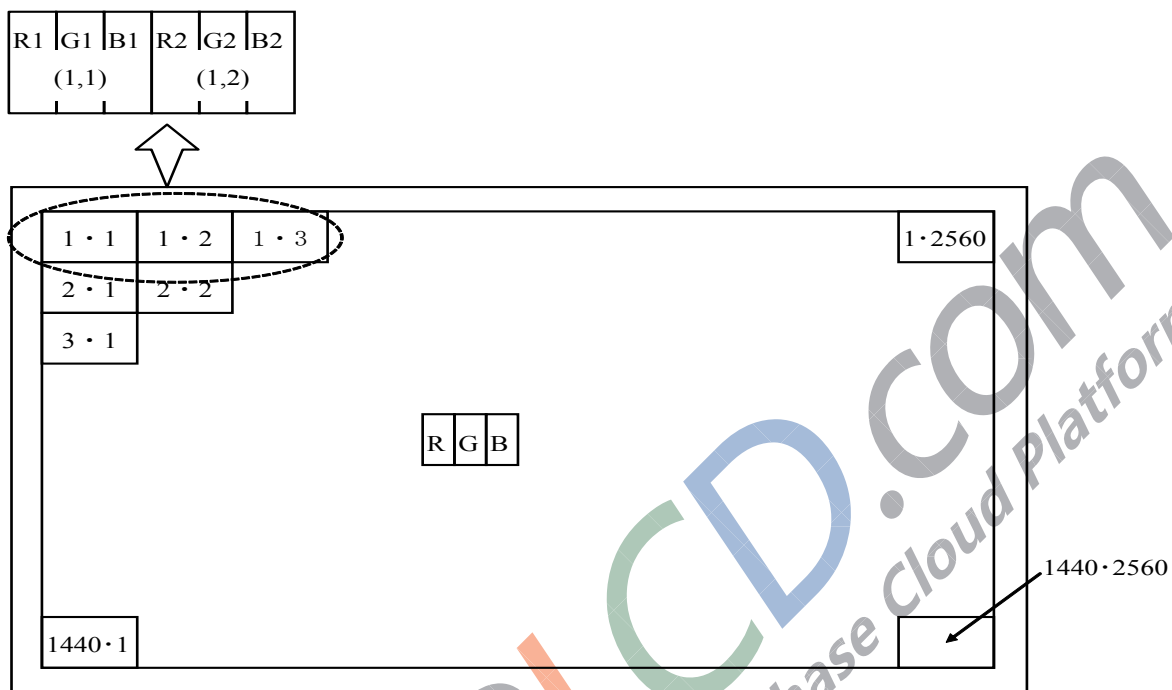

Display position of input data(V · H)



### 8. Input Signals, Basic Display Colors and Gray Scale of Each Color

Colors & Gray scale	Data signal																									
	Gray Scale	R0	R1	R2	R3	R4	R5	R6	R7	G0	G1	G2	G3	G4	G5	G6	G7	B0	B1	B2	B3	B4	B5	B6	B7	
		MSB								MSB								MSB								
Basic Color	Black	—	0	0	0	0	0	0	0	0	0	0	0	0	0	0	0	0	0	0	0	0	0	0	0	
	Blue	—	0	0	0	0	0	0	0	0	0	0	0	0	0	0	0	1	1	1	1	1	1	1	1	
	Green	—	0	0	0	0	0	0	0	1	1	1	1	1	1	1	1	0	0	0	0	0	0	0	0	
	Cyan	—	0	0	0	0	0	0	0	1	1	1	1	1	1	1	1	1	1	1	1	1	1	1	1	
	Red	—	1	1	1	1	1	1	1	0	0	0	0	0	0	0	0	0	0	0	0	0	0	0	0	
	Magenta	—	1	1	1	1	1	1	1	0	0	0	0	0	0	0	0	1	1	1	1	1	1	1	1	
	Yellow	—	1	1	1	1	1	1	1	1	1	1	1	1	1	1	1	0	0	0	0	0	0	0	0	
	White	—	1	1	1	1	1	1	1	1	1	1	1	1	1	1	1	1	1	1	1	1	1	1	1	
Gray Scale of Red	Black	GS0	0	0	0	0	0	0	0	0	0	0	0	0	0	0	0	0	0	0	0	0	0	0	0	
	↑	GS1	1	0	0	0	0	0	0	0	0	0	0	0	0	0	0	0	0	0	0	0	0	0	0	
	Darker	GS2	0	1	0	0	0	0	0	0	0	0	0	0	0	0	0	0	0	0	0	0	0	0	0	
	↑	↓	↓								↓								↓							
	↓	↓	↓								↓								↓							
	Brighter	GS253	1	0	1	1	1	1	1	1	0	0	0	0	0	0	0	0	0	0	0	0	0	0	0	
	↓	GS254	0	1	1	1	1	1	1	1	0	0	0	0	0	0	0	0	0	0	0	0	0	0	0	
	Red	GS255	1	1	1	1	1	1	1	1	0	0	0	0	0	0	0	0	0	0	0	0	0	0	0	
Gray Scale of Green	Black	GS0	0	0	0	0	0	0	0	0	0	0	0	0	0	0	0	0	0	0	0	0	0	0	0	
	↑	GS1	0	0	0	0	0	0	0	1	0	0	0	0	0	0	0	0	0	0	0	0	0	0	0	
	Darker	GS2	0	0	0	0	0	0	0	0	1	0	0	0	0	0	0	0	0	0	0	0	0	0	0	
	↑	↓	↓								↓								↓							
	↓	↓	↓								↓								↓							
	Brighter	GS253	0	0	0	0	0	0	0	0	1	0	1	1	1	1	1	1	0	0	0	0	0	0	0	
	↓	GS254	0	0	0	0	0	0	0	0	0	1	1	1	1	1	1	1	0	0	0	0	0	0	0	
	Green	GS255	0	0	0	0	0	0	0	0	1	1	1	1	1	1	1	1	0	0	0	0	0	0	0	
Gray Scale of Blue	Black	GS0	0	0	0	0	0	0	0	0	0	0	0	0	0	0	0	0	0	0	0	0	0	0	0	
	↑	GS1	0	0	0	0	0	0	0	0	0	0	0	0	0	0	0	1	0	0	0	0	0	0	0	
	Darker	GS2	0	0	0	0	0	0	0	0	0	0	0	0	0	0	0	0	1	0	0	0	0	0	0	
	↑	↓	↓								↓								↓							
	↓	↓	↓								↓								↓							
	Brighter	GS253	0	0	0	0	0	0	0	0	0	0	0	0	0	0	0	1	0	1	1	1	1	1	1	
	↓	GS254	0	0	0	0	0	0	0	0	0	0	0	0	0	0	0	0	1	1	1	1	1	1	1	
	Blue	GS255	0	0	0	0	0	0	0	0	0	0	0	0	0	0	0	1	1	1	1	1	1	1	1	

0 : Low level voltage 1 : High level voltage

Each basic color can be displayed in 256 gray scales from 8 bit data signals.

According to the combination of 24 bit data signals, the 16.7M color display can be achieved on the screen.



## 9. EDID Specification

### 9-1. EDID data structure

This is the EDID(Extended Display Identification Data) data formats to support displays as defined in the VESA Plug & Display

Byte (decimal)	Byte (hex)	Field Name and Comments	Value (hex)	Value (binary)
0	0	Header	00	00000000
1	1	Header	FF	11111111
2	2	Header	FF	11111111
3	3	Header	FF	11111111
4	4	Header	FF	11111111
5	5	Header	FF	11111111
6	6	Header	FF	11111111
7	7	Header	00	00000000
8	8	EISA manufacture code = SHP	4D	01001101
9	9	EISA manufacture code (Compressed ASCII)	10	00010000
10	0A	Product code (LQ133T1JW01 : 5108)	08	00001000
11	0B	Product code (hex,LSB first)	51	01010001
12	0C	LCD module Serial No (fixed "0")	01	00000001
13	0D	LCD module Serial No (fixed "0")	00	00000000
14	0E	LCD module Serial No (fixed "0")	00	00000000
15	0F	LCD module Serial No (fixed "0")	00	00000000
16	10	Week of manufacture (fixed "0")	1D	00011101
17	11	Year of manufacture - 1990 (ex 2000 - 1990 = 10) (fixed "0")	16	00010110
18	12	EDID structure version # = 1	01	00000001
19	13	EDID revision # = 4	04	00000100
20	14	Video i/p definition = Digital 8bit DP support	A5	10100101
21	15	Max H image size(cm) = 29cm	1D	00011101
22	16	Max V image size(cm) = 17cm	11	00010001
23	17	Display gamma (2.2 × 100) - 100 = 120	78	01111000
24	18	Feature support(stanby,suspend,RGB color/Prefer Time)	02	00000010
25	19	Red/Green Low bit(RxRy/GxGy)	EE	11101110
26	1A	Blue/White Low bit(BxBY/WxWy)	95	10010101
27	1B	Red X(Rx) (written value " ")	A3	10100011
28	1C	Red Y(Ry) (written value " ")	54	01010100
29	1D	Green X(Gx) (written value " ")	4C	01001100
30	1E	Green Y(Gy) (written value " ")	99	10011001

31	1F	Blue X(Bx) (written value " ")	26	00100110
32	20	Blue Y(By) (written value " ")	0F	00001111
33	21	White X(Wx) (written value " ")	50	01010000
34	22	White Y(Wy) (written value " ")	54	01010100
35	23	Established timings 1	00	00000000
36	24	Established timings 2	00	00000000
37	25	Established timings 3(Manufacture's reserved timing)	00	00000000
38	26	Standard timing ID1	01	00000001
39	27	Standard timing ID1	01	00000001
40	28	Standard timing ID2	01	00000001
41	29	Standard timing ID2	01	00000001
42	2A	Standard timing ID3	01	00000001
43	2B	Standard timing ID3	01	00000001
44	2C	Standard timing ID4	01	00000001
45	2D	Standard timing ID4	01	00000001
46	2E	Standard timing ID5	01	00000001
47	2F	Standard timing ID5	01	00000001
48	30	Standard timing ID6	01	00000001
49	31	Standard timing ID6	01	00000001
50	32	Standard timing ID7	01	00000001
51	33	Standard timing ID7	01	00000001
52	34	Standard timing ID8	01	00000001
53	35	Standard timing ID8	01	00000001
54	36	Detailed timing descriptor#1 fck/10000 (=241.5MHz/10000=24150=5E56h)	56	01010110
55	37	#1 fck	5E	01011110
56	38	#1 Horizontal active 2560=A00h "00h"	00	00000000
57	39	#1 Horizontal blanking 160=0A0h "A0h"	A0	10100000
58	3A	#1 Horizontal active/Horizontal blanking "A0h"	A0	10100000
59	3B	#1 Vertical active 1440=5A0h "A0h"	A0	10100000
60	3C	#1 Vertical blanking 39=027h "27h"	27	00100111
61	3D	#1 Vertical active/Vertical blanking "50h"	50	01010000
62	3E	#1 Horizontal sync , offset 48=030h "30h"	30	00110000
63	3F	#1 Horizontal sync , width 32=020h "20h"	20	00100000
64	40	#1 Vertical sync,offset / Vertical sync,width (offset=3h/width=5h)	35	00110101
65	41	#1 Horizontal sync offset/width/Vertical sync offset/width	00	00000000
66	42	#1 Horizontal image size 294mm=126h "26h"	26	00100110
67	43	#1 Vertical image size 165mm=0A5h "A5h"	A5	10100101

68	44	#1 Horizontal image size / Vertical image size "10h"	10	00010000
69	45	Horizontal boader	00	00000000
70	46	Vertical boader	00	00000000
71	47	Flags(Non-interlaced=0/non 3D=00 /Degital separate=11/Horizontal polarity/Vertical polarity="00")	18	00011000
72	48	Detailed timing descriptor #2	00	00000000
73	49	Flag	00	00000000
74	4A	Reserved	00	00000000
75	4B	Dummy Descriptor	10	00010000
76	4C	Flag	00	00000000
77	4D	1st Dummy	00	00000000
78	4E	2nd Dummy	00	00000000
79	4F	3rd Dummy	00	00000000
80	50	4th Dummy	00	00000000
81	51	5th Dummy	00	00000000
82	52	6th Dummy	00	00000000
83	53	7th Dummy	00	00000000
84	54	8th Dummy	00	00000000
85	55	9th Dummy	00	00000000
86	56	10th Dummy	00	00000000
87	57	11th Dummy	00	00000000
88	58	New line character #2 indicates end	00	00000000
89	59	Padding with "blank" character	00	00000000
90	5A	Detailed timing descriptor #3	00	00000000
91	5B	Flag	00	00000000
92	5C	Reserved	00	00000000
93	5D	Dummy Descriptor	10	00010000
94	5E	Flag	00	00000000
95	5F	1st Dummy	00	00000000
96	60	2nd Dummy	00	00000000
97	61	3rd Dummy	00	00000000
98	62	4th Dummy	00	00000000
99	63	5th Dummy	00	00000000
100	64	6th Dummy	00	00000000

101	65	7th Dummy	00	00000000
102	66	8th Dummy	00	00000000
103	67	9th Dummy	00	00000000
104	68	10th Dummy	00	00000000
105	69	11th Dummy	00	00000000
106	6A	New line character #3 indicates end	00	00000000
107	6B	Padding with "blank" character	00	00000000
108	6C	Detailed timing descriptor #4	00	00000000
109	6D	Flag	00	00000000
110	6E	Reserved	00	00000000
111	6F	Dummy descriptor	FC	11111100
112	70	Flag	00	00000000
113	71	Supplier P/N#1 (L)	4C	01001100
114	72	Supplier P/N#2 (Q)	51	01010001
115	73	Supplier P/N#3 (1)	31	00110001
116	74	Supplier P/N#4 (3)	33	00110011
117	75	Supplier P/N#5 (3)	33	00110011
118	76	Supplier P/N#6 (T)	54	01010100
119	77	Supplier P/N#7 (1)	31	00110001
120	78	Supplier P/N#8 (J)	4A	01001010
121	79	Supplier P/N#9 (W)	57	01010111
122	7A	Supplier P/N#10 (0)	30	00110000
123	7B	Supplier P/N#11 (1)	31	00110001
124	7C	Supplier P/N#12 ("Space")	0A	00001010
125	7D	(If<13 char,then terminate with ASCII code 0Ah,set remaining char 20h)	20	00100000
126	7E	Extension flag	00	00000000
127	7F	Checksum	FE	11111110

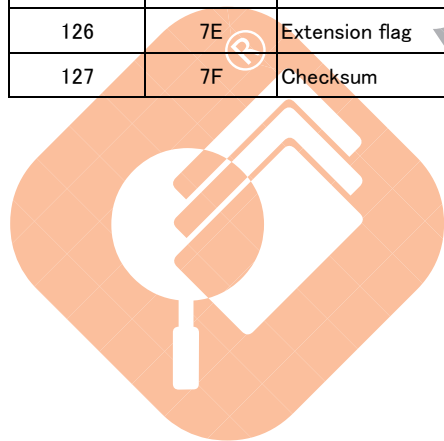

## 10. Optical specification

Ta=+25°C, VDD=+3.3V, VBL=+12V

Parameter		Symbol	Condition	Min.	Typ.	Max.	Unit	Remark
Viewing angle range	Horizontal	$\theta_{21}, \theta_{22}$	$CR \geq 10$	70	80	-	deg.	[Note 10-1, 10-3, 10-4, 10-6]
	Vertical	$\theta_{11}$		70	80	-	deg.	
		$\theta_{12}$		70	80	-	deg.	
Contrast ratio		CR	$\theta = 0^\circ$	700	1000	-		[Note 10-2, 10-4, 10-6]
Response Time		$T_{r+T_d}$	$\theta = 0^\circ$	-	25	-	ms	[Note 10-2, 10-5, 10-6]
Chromaticity of White	x			0.283	0.313	0.343		[Note 10-2, 10-6] Normal operation (PWM Duty=100%)
	y			0.299	0.329	0.359		
Chromaticity of Red	x			-	0.640	-		
	y			-	0.330	-		
Chromaticity of Green	x			-	0.300	-		
	y			-	0.600	-		
Chromaticity of Blue	x			-	0.150	-		
	y			-	0.060	-		
Luminance of white		$Y_{LI}$		240	300	-	cd/m <sup>2</sup>	
White Uniformity 13points		$\delta_w$		-	1.3	1.5		



※The measurement shall be taken 30 minutes after lighting the module at the following rating:

Condition: PWM Duty = 100%

The optical characteristics shall be measured in a dark room or equivalent.

[Note 10-1] Measuring setup for Viewing angle range and Response time

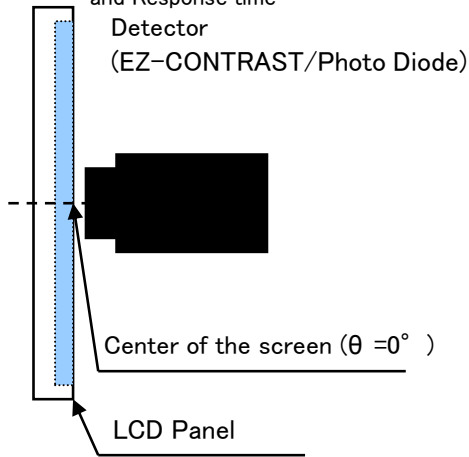

[Note 10-2] Measuring setup for Luminance, Chromaticity and Contrast.

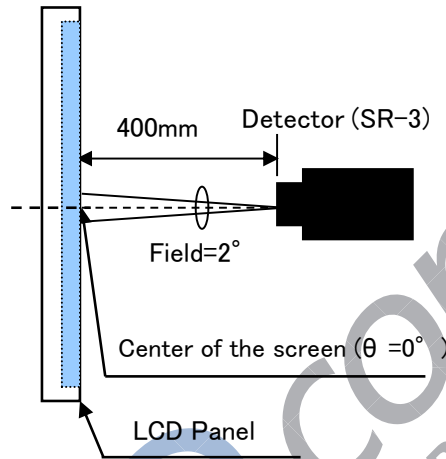

Viewing angle range: EZ-CONTRAST/Response time: Photo diode)

[Note 10-3]

Definitions of viewing angle range:

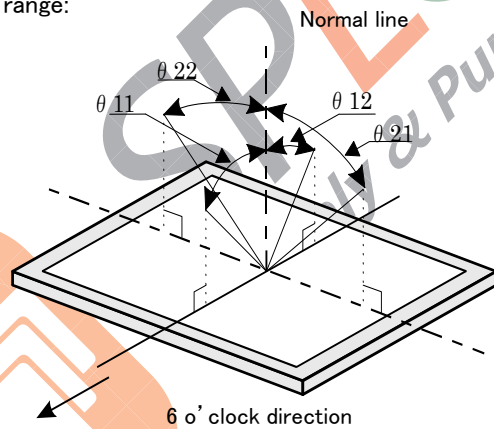

[Note 10-4]

Definition of contrast ratio:

The contrast ratio is defined as the following.

$$\text{Contrast Ratio (CR)} = \frac{\text{Luminance (brightness) with all pixels white}}{\text{Luminance (brightness) with all pixels black}}$$

[Note 10-5]

Definition of response time

The response time is defined as the following figure and shall be measured by switching the input signal for black and white .

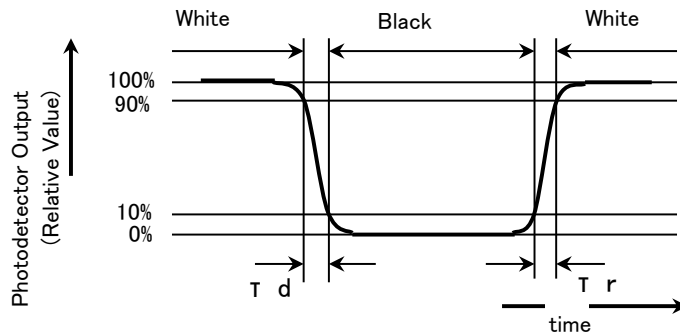

[Note 10-6]

This shall be measured at center of the screen.

[Note 10-7]

Definition of white uniformity:

White uniformity(13points) is defined as the following with 13 measurements (A~M)

$$\delta w = \frac{\text{Maximum Luminance of 13 points (brightness)}}{\text{Minimum Luminance of 13 points (brightness)}}$$

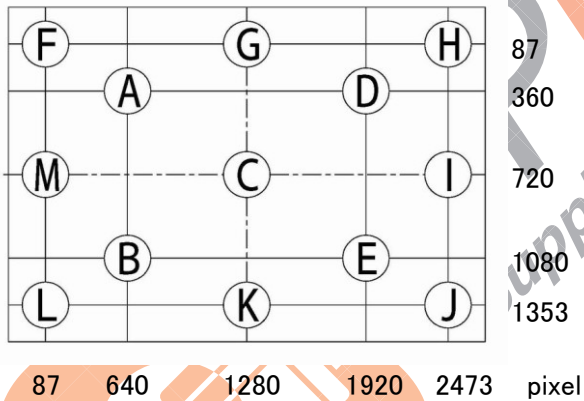

## 11. Display Qualities

The display quality of the color TFT-LCD module shall be in compliance with the Incoming Inspection Standard.

## 12. Handling Precautions

- a) Be sure to turn off the power supply when inserting or disconnecting the cable.
- b) Be sure to design the cabinet so that the module can be installed without any extra stress such as warp or twist.
- c) Since the front polarizer is easily damaged, pay attention not to scratch it.
- d) Wipe off water drop immediately. Long contact with water may cause discoloration or spots.
- e) When the panel surface is soiled, wipe it with absorbent cotton or other soft cloth.
- f) Since the panel is made of glass, it may break or crack if dropped or bumped on hard surface. Handle with care.
- g) Since CMOS LSI is used in this module, take care of static electricity and injure the human earth when handling.
- h) This module has its circuitry PCBs on the side and should be handled carefully in order not to be stressed.
- i) Protect sheet(Laminate film) is attached to the module surface to prevent it from being scratched. Peel the sheet off slowly just before the use with strict attention to electrostatic charges. Ionized air shall be blown over during the action. Blow off the 'dust' on the polarizer by using an ionized nitrogen gun, etc. Working under the following environments is desirable.
  - All workers wear conductive shoes, conductive clothes, conductive fingerstalls and grounding belts without fail.
  - Use Ionized blower for electrostatic removal, and peel of the protect sheet with a constant speed.
 (Peeling of it at over 2 seconds)
- j) In case of attaching protective board over the LCD, be careful about the optical interface fringe etc. which degrades display quality.
- k) Do not expose the LCD panel to direct sunlight. Lightproof shade etc. should be attached when LCD panel is used under such environment.
- l) When handling LCD modules and assembling them into cabinets, please be avoid that long-term storage in the environment of oxidization or deoxidization gas and the use of such materials as reagent, solvent, adhesive, resin, etc. which generate these gasses, may cause corrosion and discoloration of the LCD modules.
- m) Liquid crystal contained in the panel may leak if the LCD is broken. Rinse it as soon as possible if it gets inside your eye or mouth by mistake.
- n) Never dismantle the module, because it will cause failure. Don't change the module state written in the specification except removing Laminate film.
- o) Be careful when using it for long time with fixed pattern display as it may cause afterimage. (Please use a screen saver etc., in order to avoid an afterimage.)
- p) If a minute particle enters in the module and adheres to an optical material, it may cause display non-uniformity issue, etc. Therefore, fine-pitch filters have to be installed to cooling and inhalation hole if you intend to design a fan.
- q) Epoxy resin (amine series curing agent), silicone adhesive material (dealcoholization series and oxime series), tray forming agent (azo compound) etc, in the cabinet or the packing materials may induce abnormal display with polarizer film deterioration regardless of contact or noncontact to polarizer film. Be sure to confirm the component of them.
- r) Do not use polychloroprene. If you use it, there is some possibility of generating Cl<sub>2</sub> gas that influences the reliability of the connection between LCD panel and driver IC.
- s) Do not put a laminate film on LCD module, after peeling of the original one. If you put on it, it may cause discoloration or spots because of the occurrence of air gaps between the polarizer and the film.
- t) For stabilizing against external noise and EMI, ground to the module are recommended. If a non-grounded, check that there are no problems in the state built the product.



### 13. Packing Condition

Piling number of cartons	6
Package quantity in one carton	30
Carton size (mm)	614(W) × 426(H) × 186(D)
Total mass of one carton filled with full modules	13.5 kg
Packing form	Fig.1

### 14. Storage Conditions

Environmental condition range of storage temperature and humidity.

Temperature : 0~40°C

Relative humidity : 95% and below

[Note] Please refer below as a mean value of the environmental conditions.

Summer time temperature 20 to 35 degrees Celsius humidity , 85% and below

Winter time temperature 5 to 15 degrees Celsius humidity , 85% and below

Please maintain within 240 hours of accumulated length of storage time,

with conditions of 40 degrees Celsius and room humidity of 95%.

Direct sun light

Please keep the product in a dark room or cover the product to protect from direct sun light.

Atmospheric condition

Please refrain from keeping the product with possible corrosive gas or volatile flux.

Prevention of dew

Please store the product carton either on a wooden pallet or a stand / rack to prevent dew.

Do not place directly on the floor. In addition, to obtain moderate ventilation in between the pallet's top and bottom surfaces, pile the cartons up in a single direction and in order.

Please place the product cartons away from the storage wall.

Storage period

Within above mentioned conditions, maximum storage period should be one year.

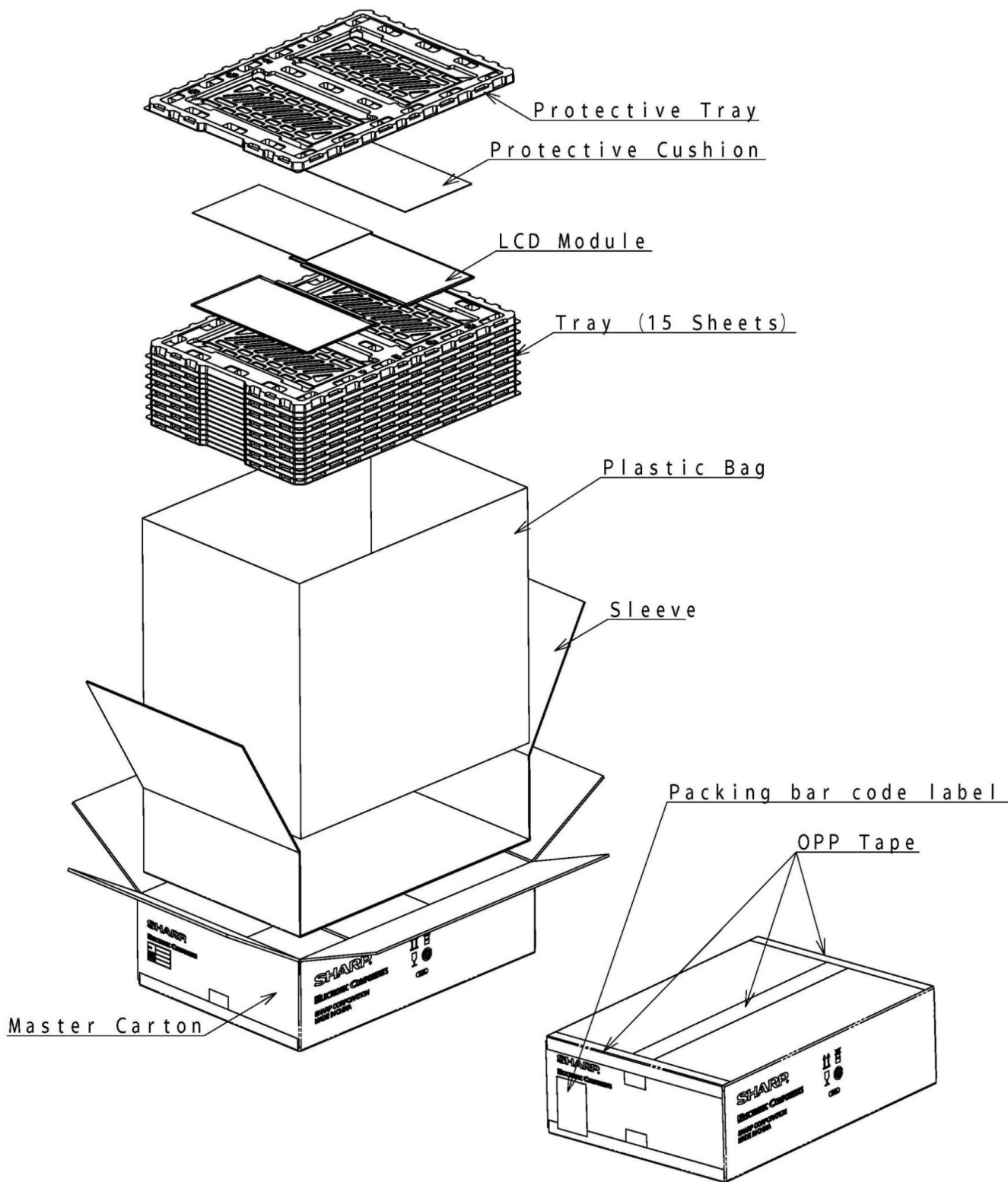
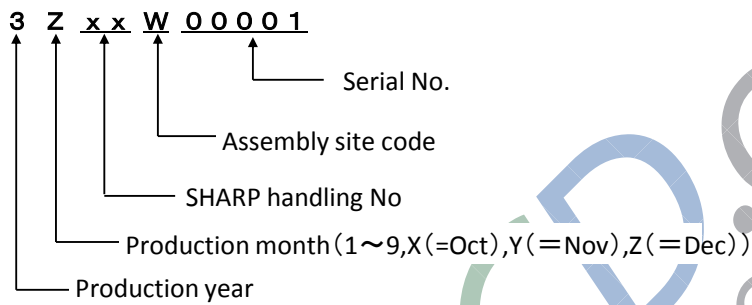
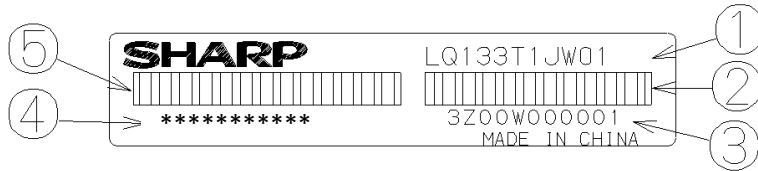

Fig. 1 Packing Form

## 15. Marking of product name

15-1) Module Bar code label:

- ① Model.No
- ② Barcode (Serial number)
- ③ Serial number
- ④ User's Model No.
- ⑤ Bardode (User's Model No.)



15-2) Packing bar code label

- ① Model.No
- ② date
- ③ Quantity (30pcs / Carton )
- ④ User's Model No.
- ⑤ Carton ID
- ⑥ management model No.

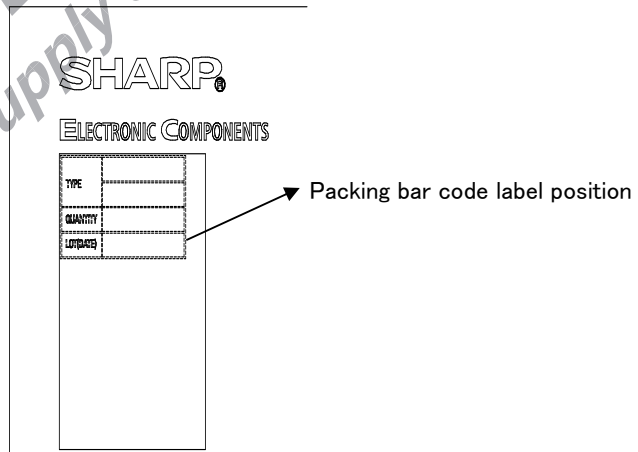
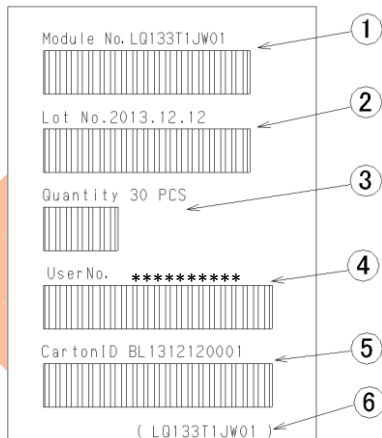

## 16. RoHS Directive

This LCD module is compliant with RoHS Directive.

RoHS conformity mark

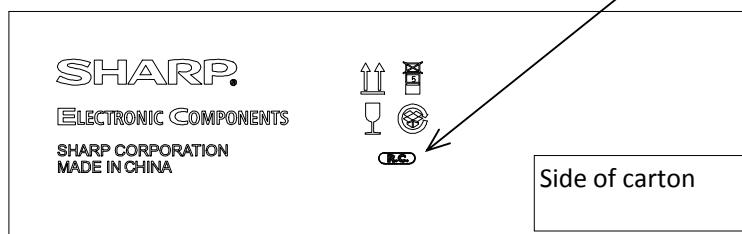

Side of carton

## 17. Reliability Test Items

### LCD module Reliability Test Items

No.	Test item	Conditions
1	High temperature storage test	Leaves the module at Ta = +60°C for 240h
2	Low temperature storage test	Leaves the module at Ta= -25°C for 240h
3	High temperature & high humidity operation test	Operates the module at Tp= +40°C ; 95%RH for 240h (No condensation)
4	High temperature operation test	Operates the module with +50°C at panel surface for 240h
5	Low temperature operation test	Operates the module at Ta= 0°C for 240h
6	Vibration test (non-operation)	Frequency : 5~22Hz/ Vibration width : 1.54mm : 22~500Hz/ Acceleration : 14.7m/s <sup>2</sup> Sweep time : 30minutes Test period : 1 hour for each direction of X,Y,Z (total 3 hours)
7	Shock test (non-operation)	1.Max. acceleration : 686m/s <sup>2</sup> , Pulse width : 11ms 2.Max. acceleration : 2352m/s <sup>2</sup> , Pulse width : 2ms Half sine wave direction : ±X,±Y,±Z Once for each direction
8	Strength against ESD	150pF [330Ω] , Panel center , Around the module . One time for each position <Contact : non-operation> ±10kV <Contact : operation> ±8kV <Air : non-operation> ±20kV <Air : operation> ±15kV

### Packaged freights Reliability Test Items

No.	Test item	Conditions
1	Vibration test	Frequency : 5-50Hz Acceleration : 9.8m/s <sup>2</sup> Sweep time : 3minutes Test period : Z, 60minutes X, 15minutes Y, 15minutes
2	Drop & Impact test	Drop height : 90cm 1 edge / 3 ridgelines / 6planes Total 10 position

#### 【Result Evaluation Criteria】

Under the display quality test conditions with normal operation state, these shall be no change which may affect practical display function.

(\*)normal operation state : Temperature:15~35°C, Humidity:45~75%, Atmospheric pressure:86~106kpa

#### 【Note17-1】

The directions of X, Y, Z are defined as below:

